

# endrichnews

www.endrich.com



Liebe Leserinnen und Leser,

Wir nähern uns der Ziellinie dieses Jahres in Windeseile. Es war ein „wildes Jahr“ mit vielen Überraschungen. Die Regierung von Donald Trump ließ uns bereits einige böse Überraschungen erwarten, aber es kam dann während des Jahres doch noch knüppeldicker als erwartet. Die Kündigung der Zollabkommen, der Marsch der Südamerikaner nach Mexiko und der vergebliche Versuch in die USA einzuwandern und vieles andere mehr. Besonders bedrückend empfand ich die sich häufenden Naturkatastrophen, von Erdbeben angefangen über kräftige Regen in Italien, Mallorca und wo immer sie sonst noch auftraten. In den letzten Monaten versiegten die Flüsse, da war kein Wasser mehr, sodass die Schifffahrt eingestellt werden musste und unsere Treibstoffversorgung auf der Kippe stand. Die von Menschenhand geschaffenen Probleme sind in diesem Jahr bei weitem übertroffen worden. Das zeigt doch, wie stark wir nach wie vor, trotz 4.0, IoT und künstlicher Intelligenz usw. eigentlich völlig den Naturgewalten ausgeliefert sind, die wir gar nicht beeinflussen können! Aber wenn wir an den CO<sup>2</sup> Ausstoß denken, eigentlich doch mit beeinflussen könnten, wenn wir denn wollten, und vor allem die Einsicht hätten. Leider gibt es immer noch Viele, die den Klimawandel in Frage stellen oder direkt leugnen. Meiner Meinung nach ist dies eine ziemlich hirnrissige Haltung.

Auch politisch hat sich bei uns in Deutschland in diesem Jahr viel getan. Die SPD rätselt, wie man neue Wähler gewinnen könnte, in Bayern ist endlich Ruhe eingetreten, Frau Merkel hat das Ende ihrer Regentschaft eingeläutet, und so könnte man eigentlich zum Alltag zurück kommen, wenn dann nicht am Himmel einige Gewitterwolken aufziehen würden, die mir gar nicht gefallen. Angefangen von den Aktienkursen, die erheblich eingebrochen sind, und zeigen, dass die Euphorie der Aktienmärkte sich ziemlich abgeschwächt hat. In Frankreich sind Unruhen entstanden, die Hr. Macron noch nicht im Griff hat, und der Brexit ist auch noch nicht ausgestanden, egal wie er sich nun schlussendlich gestalten wird. Es bleibt eine offene Frage, ob der Braunkohletagebau in Deutschland geschlossen wird. Unsere Computerwelt ist nach wie vor gefährdet durch Hackerangriffe.

Millionen von Flüchtlingen sind auf der Flucht oder auf dem Weg zu neuen Zielen in der Hoffnung auf ein besseres Leben. Dies sind nur einige Beispiele von Gedanken, die einem zum Jahresende zu denken geben sollten.

Das klingt nicht gerade heiter und passt so gar nicht zu dem „fröhlichen Weihnachten“ wie man sich es wünschen würde. Dabei sind sehr viele der oben aufgezählten Probleme nur das Werk von Menschen, von Politikern, die mit unsagbarer Machtgier versuchen, Ihren Herrschaftsanspruch weiter auszudehnen und nicht zögern, dabei auch religiöse Aspekte wie zum Beispiel den Islam oder den Kampf zwischen den Sunniten und Schiiten, dabei hemmungslos ins Spiel bringen.

Ich kann deshalb nur an die Vernunft unseren Mitmenschen appellieren, vor allem an die Regierenden, zum Wohl der Völker tätig zu sein, den Wohlstand der Völker zu fördern, aber nicht, wie in den USA „Amerika First“ überall einzuführen, sondern durch den Ausspruch „People First“, damit sind alle Menschen dieser Erde gemeint.

Mit diesen Gedanken will ich Sie nicht zu sehr beschweren, aber daran erinnern, wie zerbrechlich unser Frieden, die Globale Sicherheit und die Natur sind, und dass wir alle dazu beitragen müssen, die Kleinen, die Großen, die Armen und die Reichen, dass die Natur wieder in Einklang kommt und wir Menschen, wo immer wir sind, uns in Bescheidenheit und Zufriedenheit üben.

Ich wünsche Ihnen allen ein schönes, angenehmes und geruhsames Weihnachtsfest, Gesundheit und viel Positives im kommenden Jahr 2019.

Mit freundlichen Grüßen  
W. Endrich



## GPZ1275 SURGE PROTECTION MODULE

DC applications that include heavy duty motors, generators or where DC power is being switched on and off at frequent intervals, require TVS protection against large surges.

The GPZ1275 is a high power transient voltage suppressor designed to provide protection against long duration switching transient threats. This heavy duty device is constructed using hermetically sealed TVS sub-assemblies.

### BENEFIT

The integrated TVS Diode solution is designed to protect the interface against surge events by using one device to protect DC power lines.

### FEATURES

- Stand-Off Voltage VWM: 28 V
- Breakdown Voltage BVMIN: 32 V
- VC @ IP: 55 V @ 500 A
- Leakage Current IR: 60  $\mu$ A
- IEC 61000-4-2  $\pm$  8 kV Contact,  $\pm$  15 kV Air Discharge
- IEC 61000-4-4 EFT 40 A, 5/50 ns
- IEC 61000-4-5 Surge Secondary Lightning, 500 A @ 10/1000  $\mu$ s
- MIL-STD-1275

### APPLICATIONS

- Remote DC Power Supply, Base Station & Microwave Protection
- MIL-STD-1275 Power Bus Protection
- Electric Drive Motors & Controls
- Mobile Electronics Operating in Harsh Environment

### Buck Circuit

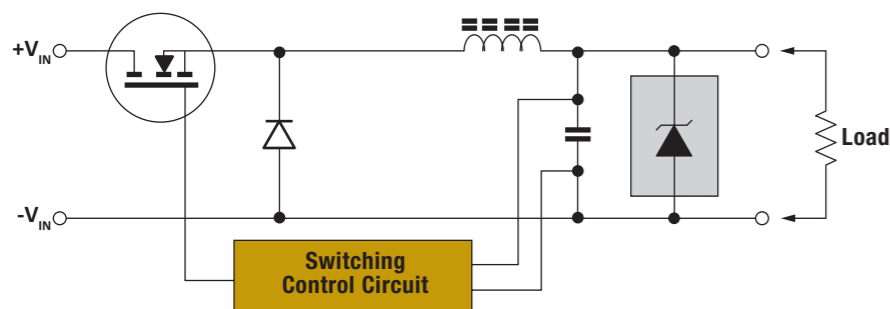

### Boost Circuit

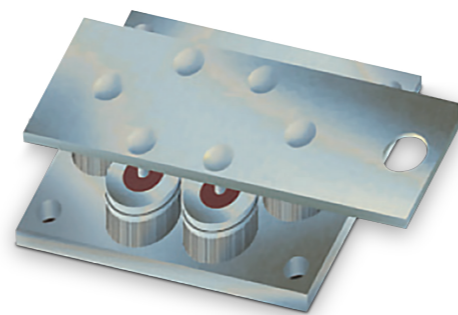
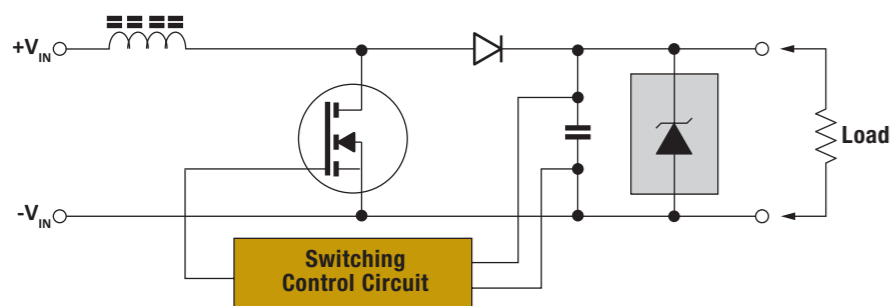

## ULTRA-HIGH PRECISION / STABILITY THIN FILM CHIP RESISTOR NETWORKS

HAVE A LOOK

### CIRCUIT TYPES

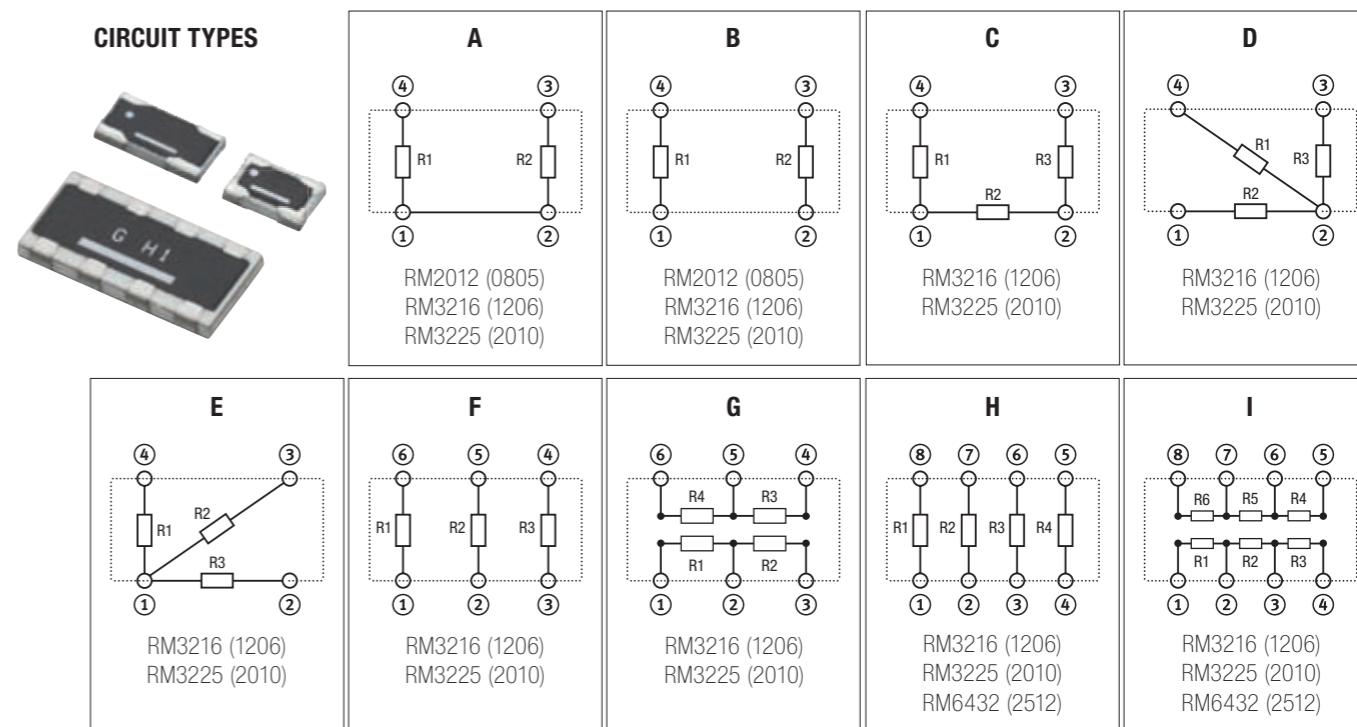

Resistance Ratio / Values: 1:1 ~ 1:500 / 100  $\Omega$  ~ 500 k $\Omega$

Tolerance (abs.) / (ratio): 0.5 % ~ 0.05 % / 0.5 % ~ 0.01 %

TCR (abs.) / (ratio): 1 ppm / K ~ 25 ppm / 0.5 ppm / K ~ 5 ppm / K

### FEATURES

- Superior reliability and stability under harsh environmental conditions
- Wide resistance range and large resistance ratio possible
- Great variety of tight tracking ratios offered
- Anti-sulfide, RoHS compliance and 100 % lead-free

### APPLICATIONS

- Precision measurement
- Analog circuits
- Voltage divider
- Test equipment
- Strain gauge
- Scales
- Industrial / medical / automotive

### RELIABILITY SPECIFICATION

ITEM	TEST METHOD (MIL-PRF-55342/JIS C5201-1)	$\Delta$ R LIMITS	
		ABSOLUTE	RATIO
Short time overload	2.5 times of rated power x 5 sec.	$\pm(0.05 \% + 0.01 \Omega)$	$\pm 0.02 \%$
Load life	85 °C, rated power, 90 min. on / 30 min. of, 1000 hours	$\pm(0.05 \% + 0.01 \Omega)$	$\pm 0.02 \%$
Temperature, humidity, bias (THB)	85 °C, 85 % RH, 1/10 of rated power, 90 min. on / 30 min. of, 2000 hours	$\pm(0.05 \% + 0.01 \Omega)$	$\pm 0.02 \%$
Thermal shock	-55 °C (30 min.) / room temp. (2 min.) / +125 °C (30 min.) / room temp. (2 min.) 1000 cycles	$\pm(0.05 \% + 0.01 \Omega)$	$\pm 0.02 \%$
High temperature exposure	155 °C for 1000 hours, no bias	$\pm(0.05 \% + 0.01 \Omega)$	$\pm 0.02 \%$

## THERMAL IMAGING ON NB-IoT POWERED BY T-SYSTEMS

Networked objects such as smart devices contain a kind of sensor and a communication module that connects them to the Internet of Things. How can we achieve an economical, technically matching and standardized network solution – “The Right Network”?

In case of short transmission paths, local area networks such as LAN, WiFi or other WLAN solutions (Bluetooth, ZigBee etc.), even near-field technologies can link devices, but for longer ranges only LoRaWAN or mobile networks can be used. When data should be routed to cloud databases and later accessed by mobile devices like laptops, tablets and cellphones, existing cellular broadband networking solutions are more convenient. However this technology soon reaches its limits, the traditional mobile spectrum of a radio cell cannot be overloaded by adding huge numbers of new non-voice subscribers (wearables, connected cars, smart meters etc).

Serving low data rates of usual smart devices via existing mobile broadband networks such as GPRS, UMTS or LTE

would be too expensive, the expected revolution of M2M & IoT requires a solution with the optimal ratio of technical features and cost efficiency.

One of the technological answers of leading providers for low power wide area networking for the M2M communications is the narrow band IoT. It is a new cellular standard of LPWAN radio networking technology based on existing LTE infrastructure. It offers connectivity of a mass of simple devices within a mobile cell, with a low data rate of 600 bits/s – 250 kbit/s as a compromise, developed primarily for transferring small amounts of (sensor) data occasionally, having low energy consumption. Advantages and key selling points are COVERAGE, BATTERY LIFE, DEVICE COST and DEEP INDOOR PENETRATION.

As cellular networks already offer very good area coverage in cities, the advantage of NB-IoT appears on field and indoor, where – due to the weaker signal-, traditional modules consume more energy. The deep indoor penetration is achieved by a higher power density, as radio transmissions are concentrated

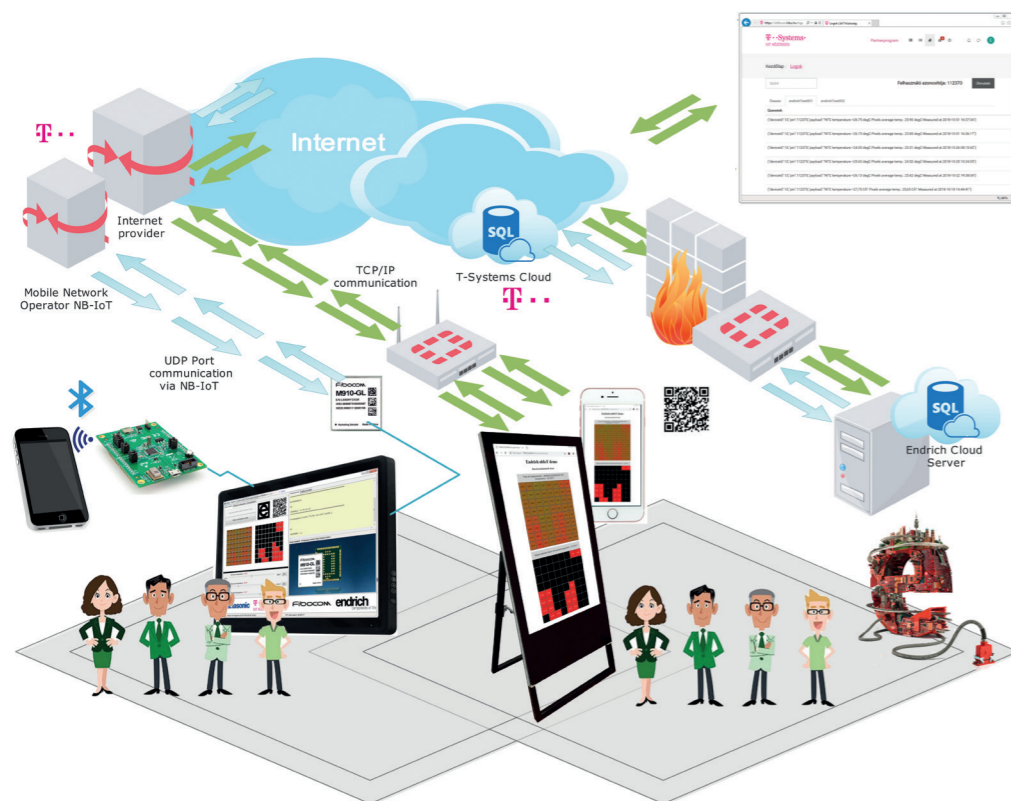

*Thermal image transferred via NB-IoT into different cloud databases and reconstructed and accessed via Internet*

## THERMAL IMAGING ON NB-IoT POWERED BY T-SYSTEMS



into a narrower carrier bandwidth, and also repetitions are possible in case of poor coverage at the expense of lower data rate. The small packages transferred in long intervals require minimal energy, thus offering the key feature of NB-IoT, the extreme long battery life. The broadband (GSM/3G/4G) modules utilize services like mobile voice, messaging and high-speed data transmission, which are not required when only low-speed but reliable data transfer is the requirement. Leaving out these functions make the modules cheaper and energy efficient.

In summary, there are strong market trends pointing at growing demand for NB-IoT applications, Endrich, together with its cellular module manufacturer Fibocom would like to be pioneers of this technology. To introduce how the infrastructure

can be set up, the Endrich booth on Electronica 2018 had offered a working NB-IoT demo application:

Panasonic's state-of-the-art GridEye thermopile array sensor detects warm objects at the booth, and its 64 pixels thermal image will be transferred by Fibocom's M910-GL LTE CAT-NB1 module via T-SYSTEM's network to different cloud services. One of the cloud server is run by T-SYSTEMS, where the average temperature of the sensor pixels and the ambient temperature is stored. Endrich has also set up a cloud server, where all pixel temperatures are sent to (via UDP port) and stored in a database. The transferred thermal picture will be displayed on visitors' Internet enabled cellular phones and a huge kiosk display from one of Endrich's panel PC supplier, Faytech.

## WHY DO YOU NEED NB-IoT?

Why do you need NB-IoT? Surely you have already asked yourself that. We would like to show you a few examples of the possibilities that are available to you with the new technology:

### SMART METERING

The remote reading of meters (such as for heating, gas, water and electricity) creates more comfort for property managers and private households. Thanks to NB-IoT, meters located in the cellar can be easily read out.

- A profitable network requires a high number of devices
- Only small amounts of data have to be transferred
- Counters are usually located in the basement of buildings where reception is difficult
- Gas/water meters are not connected to the mains and therefore need their own energy sources

### SMART WASTE MANAGEMENT

Intelligent waste management ensures that garbage cans are not emptied on a fixed schedule, but on demand. For this purpose, sensors measure the level of waste in the waste bins and send this data via NB-IoT to a cloud server for data analysis.

- Charging or frequent battery replacement of the modules is not necessary
- The location of the dumpster is flexible
- Thanks to optimized pick-up routes, logistics costs and fuel consumption of garbage collection are reduced
- Individual billing

### SMART PARKING

Studies show that up to 30 percent of city traffic is caused by motorists looking for a parking space. The result? Congestion, dissatisfaction, bad air. NarrowBand IoT enables solutions such as "Park and Joy" thanks to its low cost and long battery life.

- Easily find and pay for parking
- Less dissatisfaction among motorists
- More municipal revenues through more efficient car parking
- Less environmental impact due to lower pollutant emissions

### WHITE GOODS MONITORING

More comfort and new business models: networking so-called "white goods" such as refrigerators, dryers, ovens or dishwashers with NB-IoT has many advantages:

- Manufacturers receive usage data for market research and service purposes
- In the future consumers no longer have to buy a washing machine, for example, but can rent it cheaply and pay for each wash
- NB-IoT ensures data transmission from wash basements through good building penetration

### SMART TRACKING

Where are my goods right now? Almost everyone asks this question, who sends goods. Logistics companies offer their customers better service through tracking solutions, which can be used to track the shipping route.

- Tracking in logistics usually only requires the dispatch of small amounts of data, not necessarily in real time
- In addition to the location and the condition of the goods can also be monitored
- Valuable information gain for customs or insurance

### SMART LIGHTING

Lighting exactly where it is needed – that is what lighting management promises via NB-IoT. Municipalities and operators of highways or shopping centers can benefit from this. The new wireless standard makes the solutions cost-effective.

- Sensors detect when there are no people around, so lamps can be dimmed energy-efficient
- Comprehensive network management provides information about changes in the power grid
- Reduces energy losses and optimizes maintenance

### AIR QUALITY MONITORING

Air pollution is a ubiquitous and complex issue that affects our environment and therefore all of us. Efficient air quality monitoring helps.

- Sensors connected via NB-IoT measure pollution levels in buildings and in public spaces
- Early identification of threats allows timely countermeasures
- Higher quality of life in urban areas through safe clean air

## NEW K-LC7 RADAR TRANSCEIVER FROM RFBEAM

HAVE A LOOK

The K-LC7 from RFbeam is a small and low cost radar module which allows angle measurements. The module operates in the 24.0 GHz to 24.25 GHz ISM band and has a built in low phase noise VCO, which makes the module suitable for FSK or FMCW applications. The internal temperature compensating circuit keeps the output frequency stable over a wide temperature range.

Two receiver channels with I and Q IF outputs allow movement direction detection and high performance signal processing.

The sensor has a 3 x 4 patch radar frontend with an asymmetrical beam. The built-in voltage regulator covers a wide power supply range from 3.2 to 5.5V. The module provides a frequency divided output which can be used to measure the output frequency of the VCO.

### FEATURES

- Small and low cost 24 GHz transceiver
- Two Rx antennas for angle measurement
- I / Q IF outputs
- Fully integrated low phase noise VCO
- Built in temperature compensation circuit for VCO stabilization
- Wide power supply range from 3.2 to 5.5V
- 3 x 4 patch antenna with 80° / 34° beam aperture
- Typical detection range 30m for cars / 12 m for persons

### APPLICATIONS

- Direction sensitive movement detection
- Security systems
- Home automation
- Indoor and outdoor lighting control applications
- Object speed measurement systems
- Ranging detection of moving objects using FSK

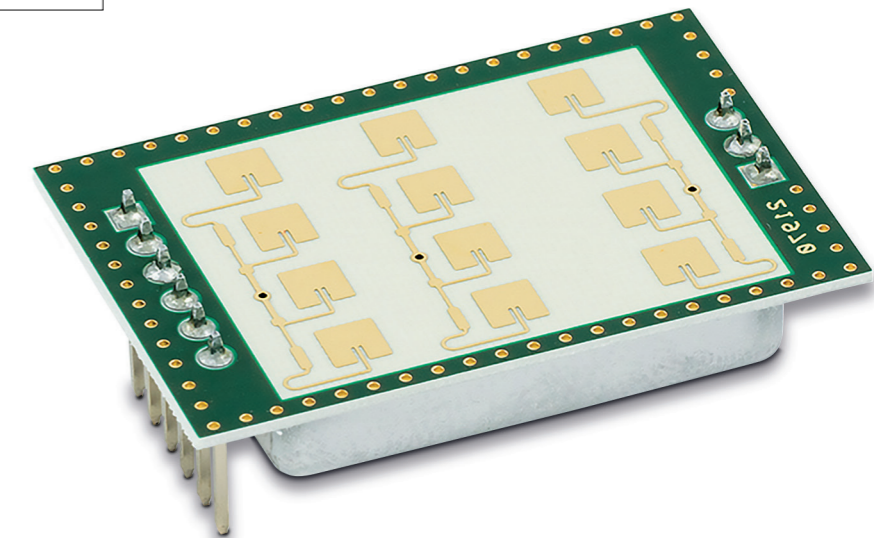
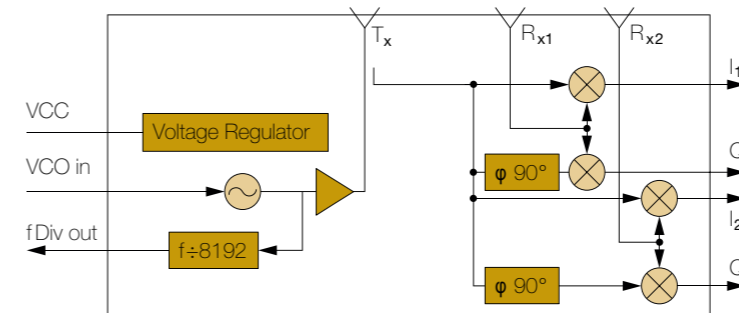

Angle measurement and movement direction detection radar transceiver in small size

# LDO WITH REVERSE CURRENT PROTECTION / DISCHARGE FUNCTION

HAVE A LOOK

The NJM2879 is a low dropout regulator which achieves high ripple rejection, low noise and high speed response with bipolar technology. Small packaging and a 0.47µF decoupling capacitor make the NJM2879 suitable for space conscious applications. Moreover, the NJM2879 is not required noise reduction capacitor. In addition, the reverse current protection makes external SBD unnecessary.

## FEATURES

- AEC-Q100 grade 1 qualified
- Operating voltage range (2.3V to 6.5V)
- Output voltage accuracy ( $V_o \pm 2.0\%$ )
- Output current ( $I_o$  (min.) = 200 mA)
- Reverse current protection
- Discharge function
- ON/OFF control
- Corresponds to low ESR capacitor (MLCC)
- Thermal shutdown circuit
- Over current protection circuit
- Package outline (SOT-23-5)

## APPLICATIONS

- Automotive infotainment
- Automotive ECU unit
- Industrial equipment

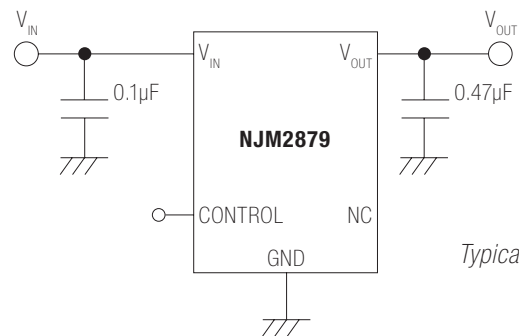

Typical circuit

PARAMETER

SYMBOL

RATINGS

## ABSOLUTE MAXIMUM RATINGS

Input Voltage	$V_{IN}$	-0.3 to +7V
Control Pin Voltage	$V_{CONT}$	-0.3 to +7V
Output Voltage	$V_{OUT}$	$V_o \leq 1.8V$ -0.3 to +5.5V $V_o > 1.8V$ -0.3 to +7V
Power Dissipation ( $T_a = 25^\circ C$ ) SOT-23-5	$P_D$	(2-layer / 4-layer) 480 <sup>(1)</sup> / 650 <sup>(2)</sup>
Junction Temperature Range	$T_j$	-40 to +150 °C
Operating Temperature Range	$T_{opr}$	-40 to +125 °C
Storage Temperature Range	$T_{stg}$	-50 to +150 °C

(1): Mounted on glass epoxy board.

(76.2 x 114.3 x 1.6 mm: based on EIA/JEDEC standard, 2-layers)

(2): Mounted on glass epoxy board.

(76.2 x 114.3 x 1.6 mm: based on EIA/JEDEC standard, 4-layers), internal Cu area: 74.2 x 74.2 mm

Contact for information: Mr. Kinn · Phone: +49(0)7452-6007-21 · e-mail: d.kinn@endrich.com

## HEADQUARTERS

ENDRICH Bauelemente Vertriebs GmbH  
P.O.Box 1251 · 72192 Nagold, Germany  
T +49 (0) 7452 6007-0  
F +49 (0) 7452 6007-70  
endrich@endrich.com  
www.endrich.com

## SALES OFFICES IN EUROPE

**France**  
Paris:  
T +33/186653215  
france@endrich.com

**Spain**  
Barcelona:  
T +34/93 217 31 44  
spain@endrich.com

**Austria & Slovenia**  
Brunn am Gebirge:  
T +43/1 665 25 25  
austria@endrich.com

**Hungary**  
Budapest:  
T +361/2 97 41 91  
hungary@endrich.com

**Lyon:**  
T +33/186653215  
france2@endrich.com

**Bulgaria**  
Sofia:  
bulgaria@endrich.com

**Romania**  
Timisoara:  
romania@endrich.com

**Switzerland – Novitronic**  
Zurich:  
T +41/44 306 91 91  
info@novitronic.ch