



CT450

XtremeSense® TMR 1 MHz Bandwidth Contactless Current Sensor with <1% Total Error

Features

- Integrated Contactless Current/Field Sensing Ranges:
 - 0 mT to +8 mT
 - -8 mT to +8 mT
 - 0 mT to +12 mT
 - -12 mT to +12 mT
 - 0 mT to +20 mT
 - -20 mT to +20 mT
- Linear Analog Output Voltage
- Total Error Output $\leq \pm 1.0\%$, -40°C to $+125^{\circ}\text{C}$
- 1 MHz Bandwidth
- Response Time $< 1.0 \mu\text{s}$
- Reference Voltage Output for Unipolar/Bipolar Field Measurements
- $V_{\text{OUT}} - V_{\text{REF}} < 1.0\%$ (Typical)
- Low Noise Performance
- Over-Field Detection (OFD™)
 - Detects Out of Range Fields
- 8-lead TSSOP Package

Applications

- Solar/Power Inverters
- Battery Management Systems
- Smart Fuse Over-Current Detection
- Industrial Equipment
- Power Utility Meters
- Power Conditioner
- DC/DC Converters

Product Description

The CT450 is a high bandwidth and low noise integrated contactless current sensor that uses Crocus Technology's patented XtremeSense TMR technology to enable high accuracy current measurements for many consumer, enterprise, and industrial applications. It supports eight (8) field ranges where the CT450 senses and translates the magnetic field into a linear analog output voltage. It achieves a total error output of less than $\pm 1.0\%$ over voltage and temperature.

It has less than $1.0 \mu\text{s}$ output response time while the current consumption is about 5.0 mA . The CT450 is equipped with over-field detection (OFD) circuitry to identify out of range fields. It has a fault-bar (FLT) pin such that if over-field faults occur, then an active LOW digital signal will be activated by the CT450 to alert the microcontroller that a fault condition has occurred.

The CT450 is a very low profile, industry standard 8-lead TSSOP package that is "green" and RoHS compliant.

Part Ordering Information

Part Number	Operating Temperature Range	Field Range	Package	Packing Method
CT450-E08DRTS08	-40°C to +85°C	0 mT to +8 mT	8-lead TSSOP 3.00 x 6.40 x 1.10 mm	Tape & Reel
CT450-H08DRTS08	-40°C to +125°C			
CT450-E08MRTS08	-40°C to +85°C	-8 mT to +8 mT	8-lead TSSOP 3.00 x 6.40 x 1.10 mm	Tape & Reel
CT450-H08MRTS08	-40°C to +125°C			
CT450-E12DRTS08	-40°C to +85°C	0 mT to +12 mT	8-lead TSSOP 3.00 x 6.40 x 1.10 mm	Tape & Reel
CT450-H12DRTS08	-40°C to +125°C			
CT450-E12MRTS08	-40°C to +85°C	-12 mT to +12 mT	8-lead TSSOP 3.00 x 6.40 x 1.10 mm	Tape & Reel
CT450-H12MRTS08	-40°C to +125°C			
CT450-E20DRTS08	-40°C to +85°C	0 mT to +20 mT	8-lead TSSOP 3.00 x 6.40 x 1.10 mm	Tape & Reel
CT450-H20DRTS08	-40°C to +125°C			
CT450-E20MRTS08	-40°C to +85°C	-20 mT to +20 mT	8-lead TSSOP 3.00 x 6.40 x 1.10 mm	Tape & Reel
CT450-H20MRTS08	-40°C to +125°C			

Evaluation Board Ordering Information

Part Number	Magnetic Field Range	Operating Temperature Range
CTD450-08U	0 mT to +8 mT	-40°C to +85°C
CTD450-08B	-8 mT to +8 mT	
CTD450-12U	0 mT to +12 mT	
CTD450-12B	-12 mT to +12 mT	
CTD450-20U	0 mT to +20 mT	
CTD450-20B	-20 mT to +20 mT	

Block Diagram

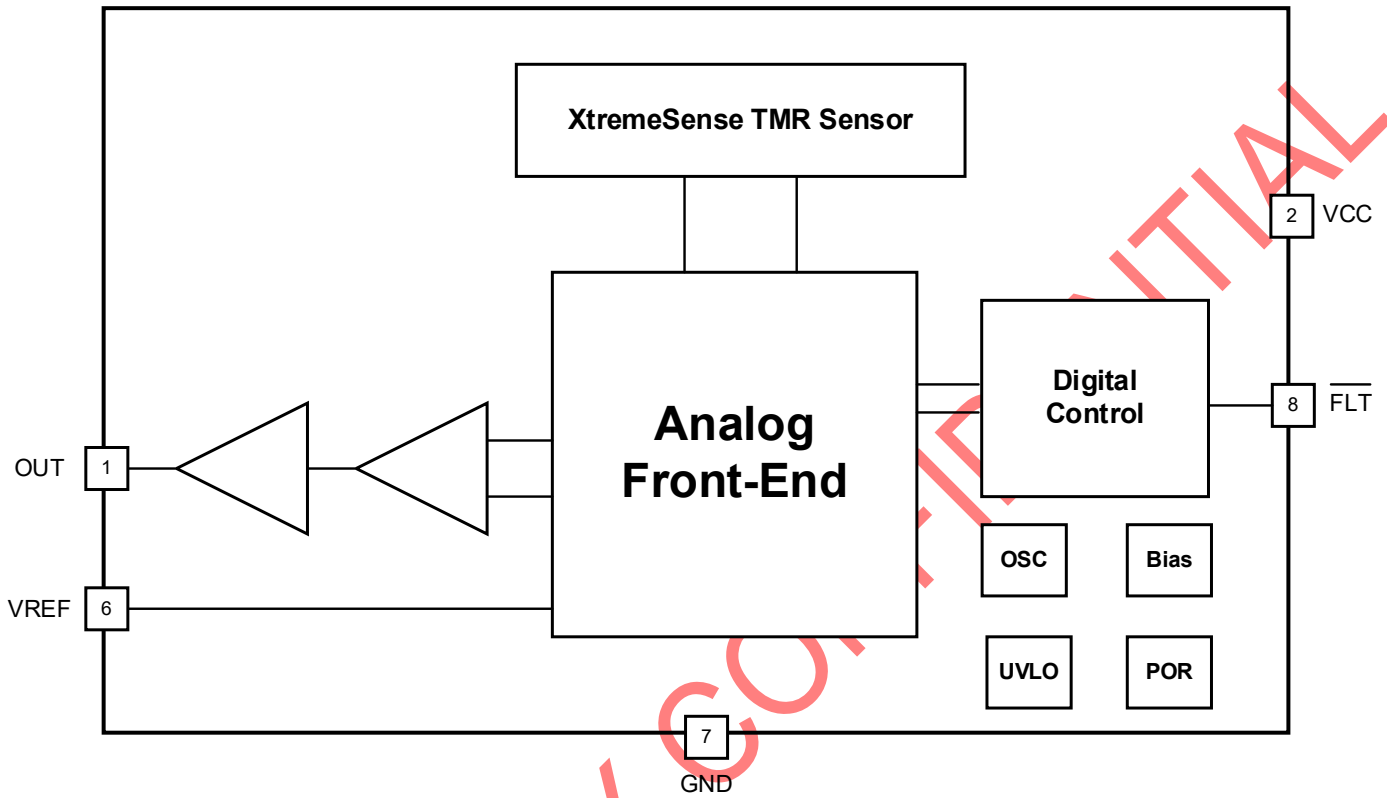

Figure 1. CT450 Functional Block Diagram

Application Diagram

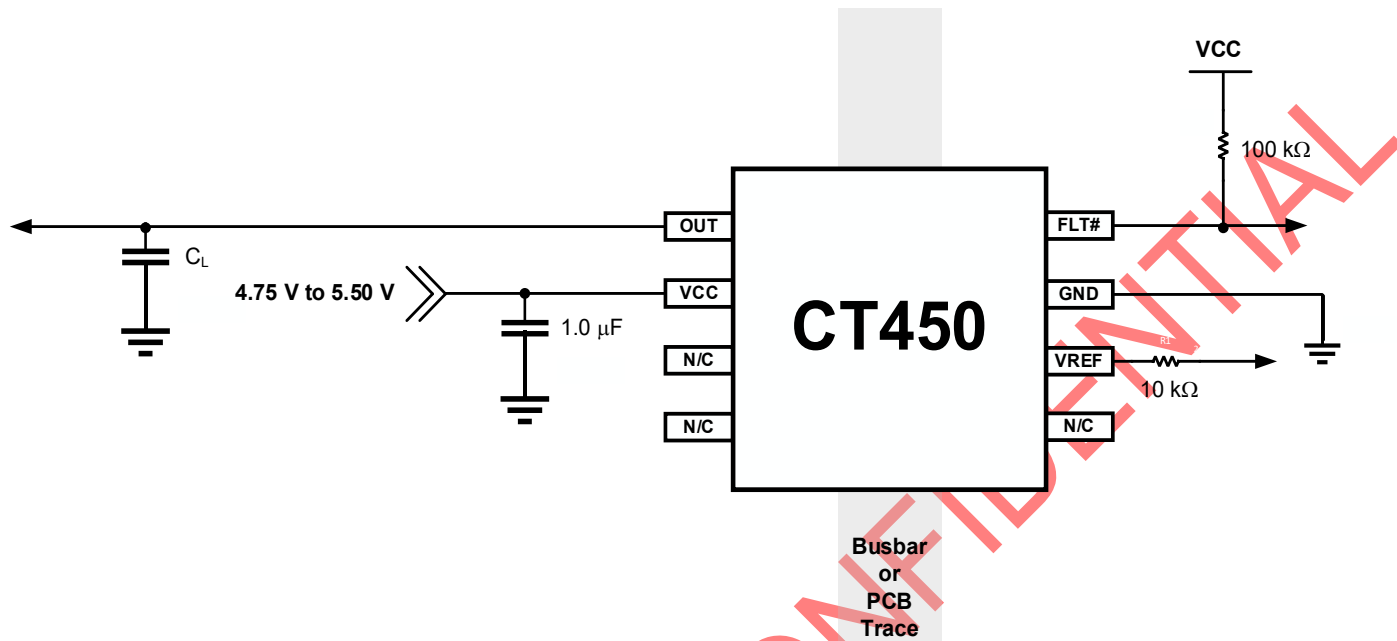

Figure 2. CT450 Application Diagram

Table 1. Recommended External Components

Component	Description	Vendor & Part Number	Parameter	Min.	Typ.	Max.	Unit
C_{BYP}	$1.0 \mu\text{F}$, X5R or Better	Murata GRM155C81A105KA12	C		1.0		μF
$R_{\text{FLT\#}}$	$100 \text{ k}\Omega$ Pull-up Resistor	Various	R1		100		$\text{k}\Omega$
R_{VREF}	$10 \text{ k}\Omega$ Resistor	Various	R2		10		$\text{k}\Omega$

CT450 TSSOP-8 Pin Configuration

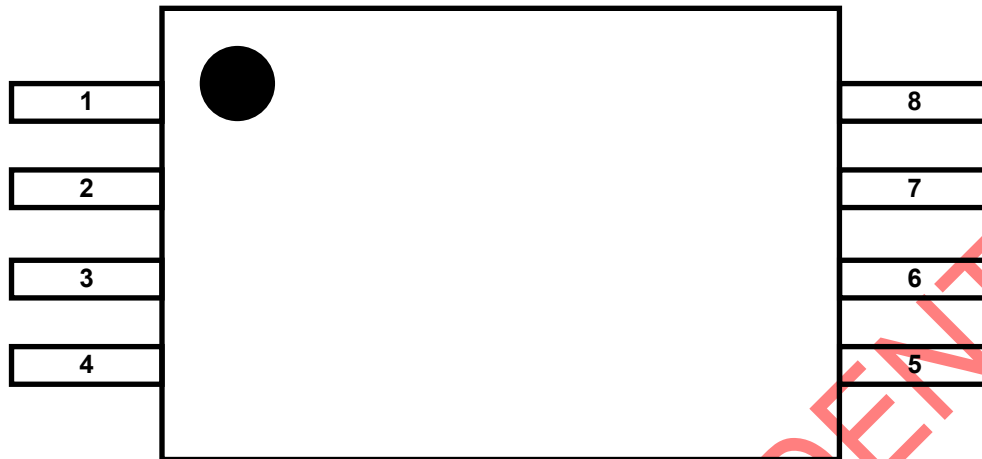

Figure 3. CT450 Pin-out Diagram for 8-lead TSSOP Package (Top-Down View)

Pin Definition

Pin #	Pin Name	Pin Description
1	OUT	Analog output voltage that represents the measured current.
2	VCC	Supply voltage.
3	N/C	No Connect.
4		
5		
6	VREF	Reference voltage output. If not used, then do not connect.
7	GND	Ground.
8	$\overline{\text{FLT}}$	Active LOW output fault signal (open drain output) to indicate that the following parameters are outside of normal operational bounds: <ul style="list-style-type: none"> Over-Field Detection (OFD) Under-Voltage Lock-out (UVLO). If not used, then do not connect.

Absolute Maximum Ratings

Stresses exceeding the absolute maximum ratings may damage the CT450 and may not function or be operable above the recommended operating conditions and stressing the parts to these levels is not recommended. In addition, extended exposure to stresses above the recommended operating conditions may affect device reliability. The absolute maximum ratings are stress ratings only.

Symbol	Parameter	Min.	Max.	Unit
V _{CC}	Supply Voltage	-0.3	6.0	V
V _{I/O}	Analog Input/Output Pins Maximum Voltage	-0.3	V _{CC} + 0.3*	V
ESD	Electrostatic Discharge Protection Level	Human Body Model (HBM) per JESD22-A114	2.0	kV
		Charged Device Model (CDM) per JESD22-C101	0.5	
T _J	Junction Temperature	-40	+150	°C
T _{STG}	Storage Temperature	-65	+155	°C
T _L	Lead Soldering Temperature, 10 Seconds		+260	°C

*The lower of V_{CC} + 0.3 V or 6.0 V.

Recommended Operating Conditions

The Recommended Operating Conditions table defines the conditions for actual operation of the CT450. Recommended operating conditions are specified to ensure optimal performance to the specifications. Crocus Technology does not recommend exceeding them or designing to absolute maximum ratings.

Symbol	Parameter	Min.	Typ.	Max.	Unit	
V _{CC}	Supply Voltage Range	4.75	5.00	5.50	V	
V _{OUT}	OUT Voltage Range	0		V _{CC}	V	
I _{OUT}	OUT Current			±1.0	mA	
T _A	Operating Ambient Temperature	Industrial	-40	+25	+85	°C
		Extended Industrial	-40	+25	+125	

Electrical Specifications

General Parameters

Unless otherwise specified: $V_{CC} = 4.75\text{ V to }5.50\text{ V}$, $T_A = -40^\circ\text{C to }+125^\circ\text{C}$, $C_{BYP} = 1.0\ \mu\text{F}$. Typical values are $V_{CC} = 5.00\text{ V}$ and $T_A = +25^\circ\text{C}$.

Symbol	Parameter	Conditions	Min.	Typ.	Max.	Unit
Power Supplies						
I_{CC}	Supply Current	$f_{BW} = 1\text{ MHz}$ No load, $B_{OP} = 0\text{ mT}$		6.0	9.0	mA
I_{OUT}	OUT Maximum Drive Capability	OUT covers 10% to 90% of V_{CC} span.	-1.0		+1.0	mA
C_{L_OUT}	OUT Capacitive Load				100	pF
R_{L_OUT}	OUT Resistive Load			100		k Ω
I_{VREF}	VREF Maximum Drive Capability		-50		+50	μA
C_{L_VREF}	VREF Capacitive Load				10	pF
R_{L_VREF}	VREF Resistive Load			100		k Ω
Analog Output (OUT)						
V_{OUT}	OUT Voltage Linear Range	$V_{SIG_AC} = \pm 2.00\text{ V}$ $V_{SIG_DC} = +4.00\text{ V}$	0.50		4.50	V
V_{OUT_SAT}	Output High Saturation Voltage	$V_{OUT}, T_A = +25^\circ\text{C}$	$V_{CC} - 0.30$	$V_{CC} - 0.25$		V
TCS	Temperature Coefficient of Sensitivity ⁽¹⁾	Absolute Value $T_A = -40^\circ\text{C to }+125^\circ\text{C}$		10	40	ppm/ $^\circ\text{C}$
TCO	Temperature Coefficient of Offset ⁽¹⁾	Absolute Value $T_A = -40^\circ\text{C to }+125^\circ\text{C}$		0.16		% FS
Reference Voltage (VREF)						
V_{REF}	Reference Voltage	Unipolar Field		0.50		V
		Bipolar Field		2.50		
Fault Output (\overline{FLT})						
$V_{FLT\#_OL}$	\overline{FLT} Voltage LOW	$I_{FLT\#_OUT} \leq 20\text{ mA}$	0		0.5	V
$I_{LEAK_FLT\#}$	High Impedance Output Leakage Current	$V_{FLT\#_OH} = V_{CC}$		5		μA
RPU	\overline{FLT} Pull-up Resistor			100		k Ω
Timings						
t_{ON}	Power-On Time	$V_{CC} \geq 4.0\text{ V}$		100	200	μs
t_{RISE}	Rise Time ⁽¹⁾	$B_{OP} = B_{OP(MAX)}$, $T_A = +25^\circ\text{C}, C_L = 100\text{ pF}$		0.7	1.0	μs
$t_{RESPONSE}$	Response Time ⁽¹⁾			0.7	1.0	μs
t_{DELAY}	Propagation Delay ⁽¹⁾			0.3		μs
Protection						
V_{UVLO}	Under-Voltage Lockout	Rising V_{CC}		2.50		V
		Falling V_{CC}		2.45		V
V_{UV_HYS}	UVLO Hysteresis			50		mV

Symbol	Parameter	Conditions	Min.	Typ.	Max.	Unit
B _{OFD_U}	Over-Field Detection for Unipolar Fields	Rising B _{OP}		1.1 × B _{OP(MAX)}		mT
		Falling B _{OP}		0.9 × B _{OP(MAX)}		mT
B _{OFD_B}	Over-Field Detection for Bipolar Fields	Rising B _{OP}		±1.1 × B _{OP(MAX)}		mT
		Falling B _{OP}		±0.9 × B _{OP(MAX)}		mT
B _{OFD_HYS}	Over-Current Detection Hysteresis			0.2 × B _{OP(MAX)}		mT

(1) Guaranteed by design and characterization; not tested in production.

PRELIMINARY CONFIDENTIAL

CT450-x08DR: 0 mT to +8 mT

Unless otherwise specified: $V_{CC} = 4.75\text{ V to }5.50\text{ V}$, $T_A = -40^\circ\text{C to }+125^\circ\text{C}$, $C_{BYP} = 1.0\ \mu\text{F}$. Typical values are $V_{CC} = 5.00\text{ V}$ and $T_A = +25^\circ\text{C}$.

Symbol	Parameter	Conditions	Min.	Typ.	Max.	Unit
B_{RANGE}	Magnetic Field Range		0		+8	mT
V_{OQ}	Voltage Output Quiescent	$T_A = +25^\circ\text{C}$, $B_{OP} = 0\text{ mT}$	0.495	0.500	0.505	V
$V_{OUT} - V_{REF}$	OUT – VREF Offset Voltage	$V_{CC} = 5.0\text{ V}$ $T_A = -40^\circ\text{C to }+125^\circ\text{C}$			TBD	mV
S	Sensitivity	$B_{RANGE(MIN)} < B_{OP} < B_{RANGE(MAX)}$		500		mV/mT
E_{OUT}	Total Output Error	$B_{OP} = \text{Entire } B_{OP}\text{ Range}$ $T_A = -40^\circ\text{C to }+125^\circ\text{C}$		± 1.0		% FS
E_{LIN}	Non-Linearity Error	$B_{OP} = 0\text{ mT to }+8\text{ mT}$		± 0.3		% FS
f_{BW}	Bandwidth	Small Signal = -3 dB		1.0		MHz
e_N	Noise ⁽¹⁾	$T_A = +25^\circ\text{C}$, $f_{BW} = 100\text{ kHz}$		TBD		mV _{RMS}

(1) Guaranteed by design and characterization; not tested in production.

CT450-x08MR: -8 mT to +8 mT

Unless otherwise specified: $V_{CC} = 4.75\text{ V to }5.50\text{ V}$, $T_A = -40^\circ\text{C to }+125^\circ\text{C}$, $C_{BYP} = 1.0\ \mu\text{F}$. Typical values are $V_{CC} = 5.00\text{ V}$ and $T_A = +25^\circ\text{C}$.

Symbol	Parameter	Conditions	Min.	Typ.	Max.	Unit
B_{RANGE}	Magnetic Field Range		-8		+8	mT
V_{OQ}	Voltage Output Quiescent	$T_A = +25^\circ\text{C}$, $B_{OP} = 0\text{ mT}$	2.490	2.500	2.510	V
$V_{OUT} - V_{REF}$	OUT – VREF Offset Voltage	$V_{CC} = 5.0\text{ V}$ $T_A = -40^\circ\text{C to }+125^\circ\text{C}$			TBD	mV
S	Sensitivity	$B_{RANGE(MIN)} < B_{OP} < B_{RANGE(MAX)}$		250		mV/mT
E_{OUT}	Total Output Error	$B_{OP} = \text{Entire } B_{OP}\text{ Range}$ $T_A = -40^\circ\text{C to }+125^\circ\text{C}$		± 1.0		% FS
E_{LIN}	Non-Linearity Error	$B_{OP} = -8\text{ mT to }+8\text{ mT}$		± 0.3		% FS
f_{BW}	Bandwidth	Small Signal = -3 dB		1.0		MHz
e_N	Noise ⁽¹⁾	$T_A = +25^\circ\text{C}$, $f_{BW} = 100\text{ kHz}$		TBD		mV _{RMS}

(1) Guaranteed by design and characterization; not tested in production.

CT450-x12DR: 0 mT to +12 mT

Unless otherwise specified: $V_{CC} = 4.75\text{ V to }5.50\text{ V}$, $T_A = -40^\circ\text{C to }+125^\circ\text{C}$, $C_{BYP} = 1.0\ \mu\text{F}$. Typical values are $V_{CC} = 5.00\text{ V}$ and $T_A = +25^\circ\text{C}$.

Symbol	Parameter	Conditions	Min.	Typ.	Max.	Unit
B_{RANGE}	Magnetic Field Range		0		+12	mT
V_{OQ}	Voltage Output Quiescent	$T_A = +25^\circ\text{C}$, $B_{OP} = 0\text{ mT}$	0.495	0.500	0.505	V
$V_{OUT} - V_{REF}$	OUT – VREF Offset Voltage	$V_{CC} = 5.0\text{ V}$ $T_A = -40^\circ\text{C to }+125^\circ\text{C}$			TBD	mV
S	Sensitivity	$B_{RANGE(MIN)} < B_{OP} < B_{RANGE(MAX)}$		333		mV/mT
E_{OUT}	Total Output Error	$B_{OP} = \text{Entire } B_{OP} \text{ Range}$ $T_A = -40^\circ\text{C to }+125^\circ\text{C}$		± 0.5	± 1.0	% FS
E_{LIN}	Non-Linearity Error	$B_{OP} = 0\text{ mT to }+12\text{ mT}$		± 0.3	± 0.5	% FS
f_{BW}	Bandwidth	Small Signal = -3 dB		1.0		MHz
e_N	Noise ⁽¹⁾	$T_A = +25^\circ\text{C}$, $f_{BW} = 100\text{ kHz}$		TBD		mV _{RMS}

(1) Guaranteed by design and characterization; not tested in production.

CT450-x12MR: -12 mT to +12 mT

Unless otherwise specified: $V_{CC} = 4.75\text{ V to }5.50\text{ V}$, $T_A = -40^\circ\text{C to }+125^\circ\text{C}$, $C_{BYP} = 1.0\ \mu\text{F}$. Typical values are $V_{CC} = 5.00\text{ V}$ and $T_A = +25^\circ\text{C}$.

Symbol	Parameter	Conditions	Min.	Typ.	Max.	Unit
B_{RANGE}	Magnetic Field Range		-12		+12	mT
V_{OQ}	Voltage Output Quiescent	$T_A = +25^\circ\text{C}$, $B_{OP} = 0\text{ mT}$	2.490	2.500	2.510	V
$V_{OUT} - V_{REF}$	OUT – VREF Offset Voltage	$V_{CC} = 5.0\text{ V}$ $T_A = -40^\circ\text{C to }+125^\circ\text{C}$			TBD	mV
S	Sensitivity	$B_{RANGE(MIN)} < B_{OP} < B_{RANGE(MAX)}$		167		mV/mT
E_{OUT}	Total Output Error	$B_{OP} = \text{Entire } B_{OP} \text{ Range}$ $T_A = -40^\circ\text{C to }+125^\circ\text{C}$		± 0.5	± 1.0	% FS
E_{LIN}	Non-Linearity Error	$B_{OP} = -12\text{ mT to }+12\text{ mT}$		± 0.3	± 0.5	% FS
f_{BW}	Bandwidth	Small Signal = -3 dB		1.0		MHz
e_N	Noise ⁽¹⁾	$T_A = +25^\circ\text{C}$, $f_{BW} = 100\text{ kHz}$		TBD		mV _{RMS}

(1) Guaranteed by design and characterization; not tested in production.

CT450-x20DR: 0 mT to +20 mT

Unless otherwise specified: $V_{CC} = 4.75\text{ V to }5.50\text{ V}$, $T_A = -40^\circ\text{C to }+125^\circ\text{C}$, $C_{BYP} = 1.0\ \mu\text{F}$. Typical values are $V_{CC} = 5.00\text{ V}$ and $T_A = +25^\circ\text{C}$.

Symbol	Parameter	Conditions	Min.	Typ.	Max.	Unit
B _{RANGE}	Magnetic Field Range		0		+20	mT
V _{OQ}	Voltage Output Quiescent	$T_A = +25^\circ\text{C}$, $B_{OP} = 0\text{ mT}$	0.495	0.500	0.505	V
V _{OUT} - V _{REF}	OUT – VREF Offset Voltage	$V_{CC} = 5.0\text{ V}$ $T_A = -40^\circ\text{C to }+125^\circ\text{C}$			TBD	mV
S	Sensitivity	$B_{RANGE(MIN)} < B_{OP} < B_{RANGE(MAX)}$		200		mV/mT
E _{OUT}	Total Output Error	$B_{OP} = \text{Entire } B_{OP}\text{ Range}$ $T_A = -40^\circ\text{C to }+125^\circ\text{C}$		± 0.5	± 1.0	% FS
E _{LIN}	Non-Linearity Error	$B_{OP} = 0\text{ mT to }+20\text{ mT}$		± 0.3	± 0.5	% FS
f _{BW}	Bandwidth	Small Signal = -3 dB		1.0		MHz
e _N	Noise ⁽¹⁾	$T_A = +25^\circ\text{C}$, $f_{BW} = 100\text{ kHz}$		TBD		mV _{RMS}

(1) Guaranteed by design and characterization; not tested in production.

CT450-x20MR: -20 mT to +20 mT

Unless otherwise specified: $V_{CC} = 4.75\text{ V to }5.50\text{ V}$, $T_A = -40^\circ\text{C to }+125^\circ\text{C}$, $C_{BYP} = 1.0\ \mu\text{F}$. Typical values are $V_{CC} = 5.00\text{ V}$ and $T_A = +25^\circ\text{C}$.

Symbol	Parameter	Conditions	Min.	Typ.	Max.	Unit
B _{RANGE}	Magnetic Field Range		-20		+20	mT
V _{OQ}	Voltage Output Quiescent	$T_A = +25^\circ\text{C}$, $B_{OP} = 0\text{ mT}$	2.490	2.500	2.510	V
V _{OUT} - V _{REF}	OUT – VREF Offset Voltage	$V_{CC} = 5.0\text{ V}$ $T_A = -40^\circ\text{C to }+125^\circ\text{C}$			TBD	mV
S	Sensitivity	$B_{RANGE(MIN)} < B_{OP} < B_{RANGE(MAX)}$		100		mV/mT
E _{OUT}	Total Output Error	$B_{OP} = \text{Entire } B_{OP}\text{ Range}$ $T_A = -40^\circ\text{C to }+125^\circ\text{C}$		± 0.5	± 1.0	% FS
E _{LIN}	Non-Linearity Error	$B_{OP} = -20\text{ mT to }+20\text{ mT}$		± 0.3	± 0.5	% FS
f _{BW}	Bandwidth	Small Signal = -3 dB		1.0		MHz
e _N	Noise ⁽¹⁾	$T_A = +25^\circ\text{C}$, $f_{BW} = 100\text{ kHz}$		TBD		mV _{RMS}

(1) Guaranteed by design and characterization; not tested in production.

Circuit Description

Overview

The CT450 is a very high accuracy contactless current sensor that can sense magnetic fields from 8 mT to 20 mT. It has very high sensitivity and a wide dynamic range with excellent accuracy (very low total output error) across temperature. This current sensor supports six (6) field ranges:

- 0 mT to +8 mT
- -8 mT to +8 mT
- 0 mT to +12 mT
- -12 mT to +12 mT
- 0 mT to 20 mT
- -20 mT to +20 mT

When current is flowing through a busbar above or below the CT450, the XtenseSense TMR sensor inside the chip senses the field which in turn generates a differential voltage signals that then goes through the Analog Front-End (AFE) to output a current measurement as low as $\pm 1.0\%$ full-scale (FS) total output error (E_{OUT}).

The chip is designed to enable a very fast response time of $0.7 \mu\text{s}$ for the current measurement from the OUT pin as the bandwidth for the CT450 is 1.0 MHz. Even with a high bandwidth, the chip consumes a minimal amount of power.

Linear Output Magnetic Field Measurement

The CT450 provides a continuous linear analog output voltage which represents the magnetic field generated by the current flowing through the busbar. The output voltage range of OUT is from 0.50 V to 4.50 V with a V_{OQ} of 0.50 V and 2.50 V for unidirectional and bidirectional fields, respectively. Figure 4 illustrates the output voltage range of the OUT pin as a function of the measured field.

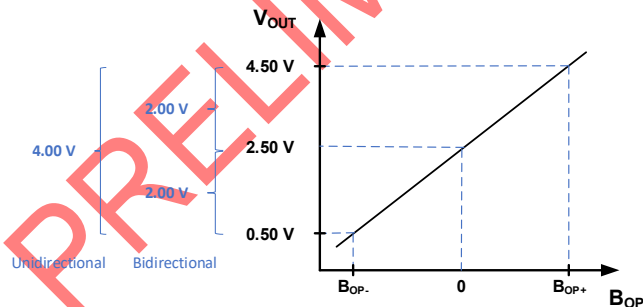

Figure 4. Linear Output Voltage Range (OUT) vs. Measured Magnetic Field (B_{OP})

Voltage Reference Function (VREF)

The CT450 has a reference voltage (VREF) pin that may be used as an output voltage reference for AC or DC field/current measurements. The VREF pin should be connected to a buffer circuit.

If the VREF is not used, then it should be left unconnected.

Total Output Error

The Total Output Error is the difference between the magnetic field measured by CT450 and the actual field, relative to the actual field. It is equivalent to the ratio between the difference of the ideal and actual voltage to the ideal sensitivity multiplied by the magnetic field due to current flowing through the busbar. The equation below defines the Total Output Error (E_{OUT}) for the CT450:

$$E_{OUT} = \frac{V_{OUT_IDEAL}(B_{OP}) - V_{OUT}(B_{OP})}{S_{IDEAL}(B_{OP}) \times B_{OP}}$$

The E_{OUT} incorporates all sources of error and is a function of the sensed magnetic field (B_{OP}) from CT450. At high field levels, the E_{OUT} will be dominated by the sensitivity error whereas at low fields, the dominant characteristic is the offset voltage. Figure 5 shows the behavior of E_{OUT} versus B_{OP} . When B_{OP} goes 0 from both directions, the curves exhibit asymptotic behavior i.e. E_{OUT} approaches infinity.

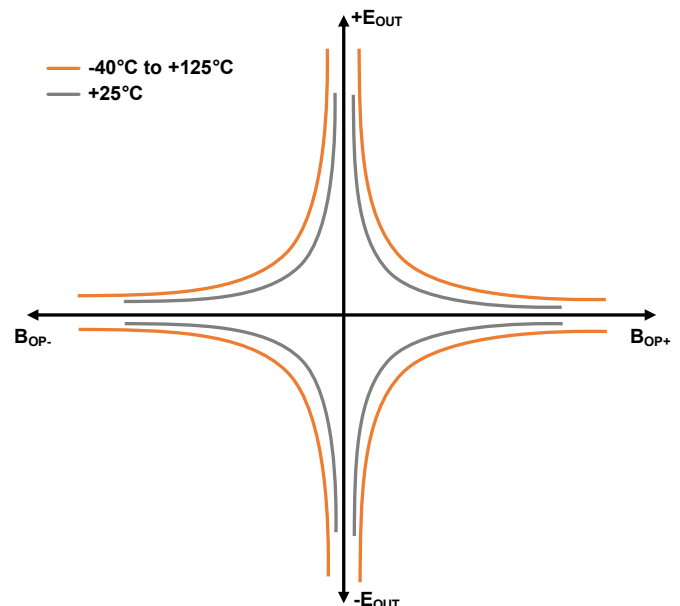

Figure 5. Total Output Error (E_{OUT}) vs. Field (B_{OP})

The CT450 achieves a total output error (E_{OUT}) that is less than $\pm 1.0\%$ of Full-Scale (FS) over supply voltage and temperature. It is designed with innovative and proprietary TMR sensors and circuit blocks to provide very accurate magnetic field measurements regardless of the operating conditions.

Power-On Time (t_{ON})

The Power-On Time (t_{ON}) of 100 μs is the amount of time required by CT450 to start up, fully power the chip and becoming fully operational from the moment the supply voltage is applied to it. This time includes the ramp up time and the settling time (within 10% of steady-state voltage under an applied magnetic field) after the power supply have reach the minimum V_{CC} .

Response Time ($t_{RESPONSE}$)

The Response Time ($t_{RESPONSE}$) of 0.7 μs for the CT450 is the time interval between the following terms:

1. When the primary field/current signal reaches 90% of its final value,
2. When the chip reaches 90% of its output corresponding to the applied field/current.

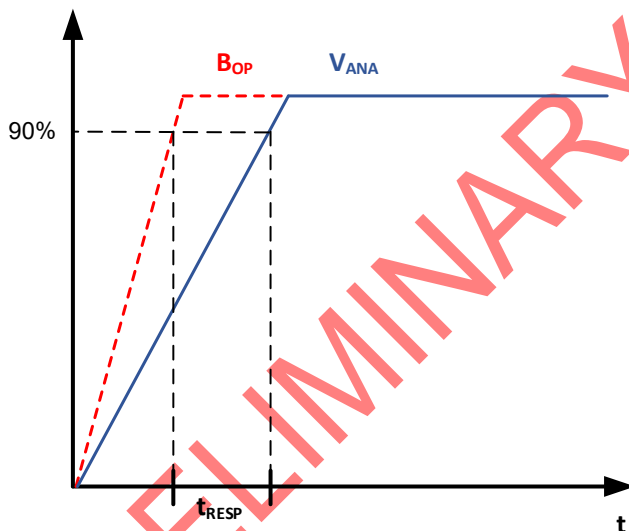

Figure 6. CT450 Response Time Curve

Rise Time (t_{RISE})

The CT450's rise time, t_{RISE} , is the time interval of when it reaches 10% and 90% of the full-scale output voltage. The t_{RISE} of the CT450 is 0.7 μs .

Propagation Delay (t_{DELAY})

The Propagation Delay (t_{DELAY}) is the time difference between these two events:

1. When the primary current reaches 20% of its final value
2. When the chip reaches 20% of its output corresponding to the applied field/current.

The CT450 has a propagation delay of 0.3 μs .

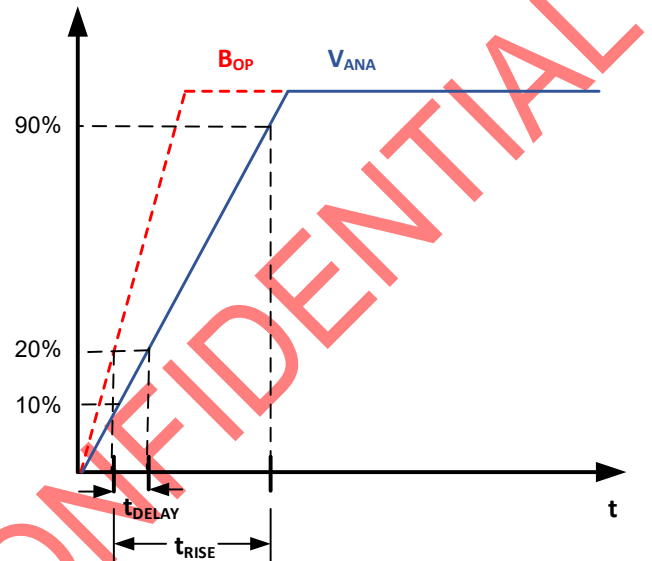

Figure 7. CT450 Propagation Delay and Rise Time Curve

Over-Field Detection (OFD)

The Over-Field Detection (OFD) circuitry detects the measured magnetic field values that are 110% above the maximum field range value of the CT450. This will generate a fault signal via the Fault# Interrupt (\overline{FLT}) pin (LOW) to the host system's microcontroller. Once the measured current falls to 90% of the maximum current range then the fault will be cleared, and the \overline{FLT} pin will go HIGH.

When magnetic field is 110% maximum field range, the OUT voltage is greater than 4.5 V for unipolar (DC) and $>4.5 V / <0.5 V$ for bipolar (AC).

Under-Voltage Lockout (UVLO)

The Under-Voltage Lock-out protection circuitry of the CT450 is activated when the supply voltage (V_{CC}) falls below 2.45 V. The CT450 remains in a low quiescent state until V_{CC} rises above the UVLO threshold (2.50 V). In this condition where the V_{CC} is less than 2.45 V and UVLO is triggered, the output from the CT450 is not valid and the \overline{FLT} pin will go LOW. Once the V_{CC} rises above 4.0 V then the UVLO is cleared, and the \overline{FLT} pin will be HIGH.

Fault# Interrupt (\overline{FLT})

The CT450 generates an active LOW digital fault signal via the \overline{FLT} pin to interrupt the microcontroller to indicate

a fault event has been triggered. It is an open drain output and requires a pull-up resistor with a value of 100 kΩ tied to V_{CC}. A fault signal will interrupt the host system for these events:

- OFD
- UVLO

The $\overline{\text{FLT}}$ signal will be asserted LOW whenever one of the above fault events occur. In the case of a UVLO event, the $\overline{\text{FLT}}$ pin will stay LOW until the fault is cleared and then go HIGH.

CT450 Calibration Guide

Introduction

All current sensors, no matter how expensive they are, or what materials they use, or even if they were factory calibrated, are susceptible to deviations from their Ideal Transfer Line.

To extract the absolute best performance from any current sensing system, calibration is required.

Ideal Transfer Line

Ideally, the sensor output follows a straight line, has a fixed slope, and crosses a fix offset point. This allows the user to apply a straightforward linear equation to extract the “physical” value being measured. In the case of a current sensor:

$$\text{Current} = \frac{\text{Voltage} - b}{a}$$

where a: slope and b: offset of the ideal curve. In a perfect sensor, both a and b coefficients can be simply looked up on the datasheet.

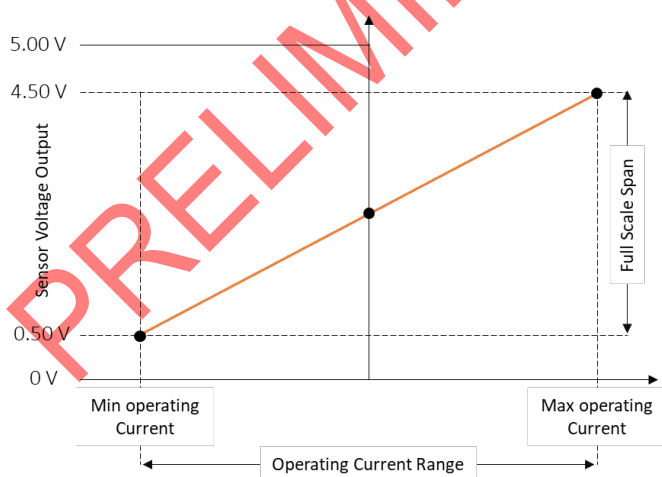

Figure 8. Ideal Transfer Line

Any deviation from this Ideal Line are considered sensor errors. More specifically Accuracy Errors as they related in the case of Crocus Technology’s sensors to Gain and Offset errors.

Offset Error

Based on the Ideal Transfer Line, when no current is applied, the voltage output of the sensor should be equal to 2.50 V. On the datasheet, the user can find the spread (i.e. min-max) values of offsets of Crocus Technology’s products.

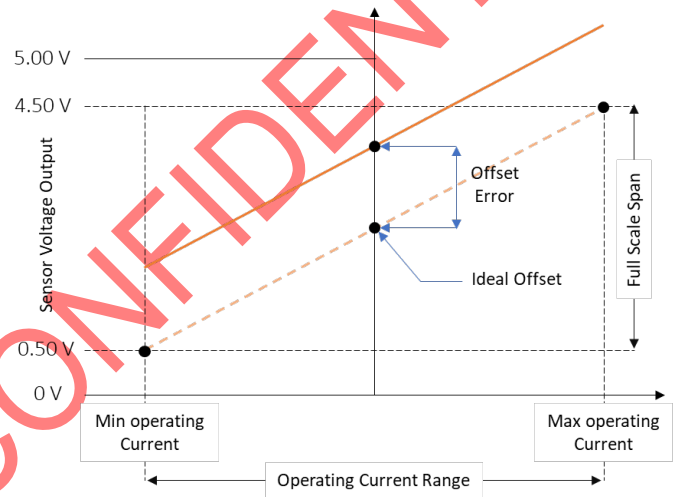

Figure 9. Exaggerated Offset Error

Gain Error

The Ideal Transfer Line shows a line that reaches 4.50 V at the maximum operating current and 0.50 V at the minimum. The datasheet also shows the spread of the gain found on the sensors.

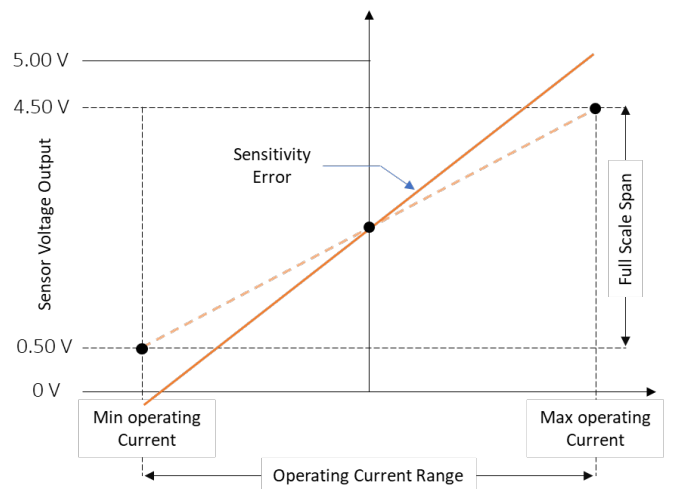

Figure 10. Exaggerated Gain Error

Calibration

Different methods can be applied for offset and/or gain correction. The complexity of these methods lead to different calibration results. The higher the complexity the better the error correction is.

Simple Offset Correction

Offset calibration is achieved simply by storing the voltage output of the sensor at zero flowing current.

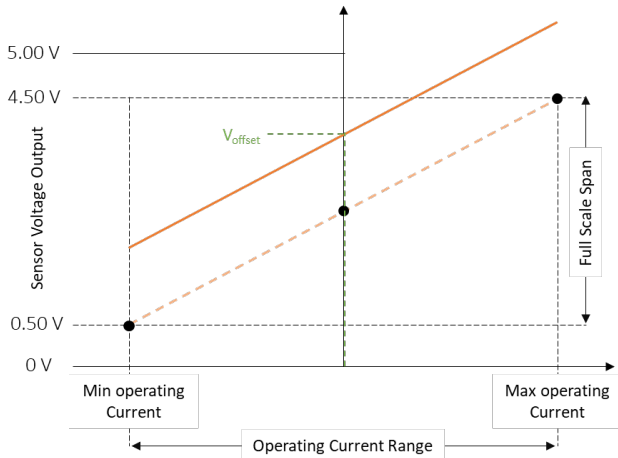

Figure 11. Simple Offset Calibration

This stored value V_{OFFSET} becomes the coefficient “b” in the linear transfer function:

$$Current = \frac{Voltage - b}{a}$$

Simple Gain Correction

Basic Gain calibration can be achieved by applying a known current value (A_1) and measure the sensor output voltage value (V_1)

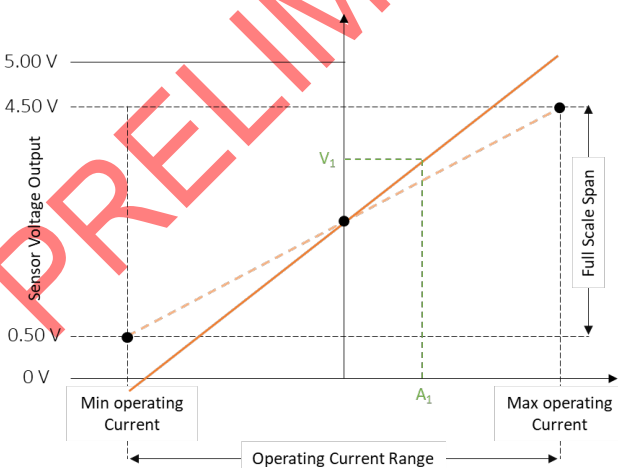

Figure 12. Simple Gain Calibration

The following equation is used to calculate the slope coefficient “a”:

$$a = \frac{V_1 - V_{OFFSET}}{A_1}$$

Recommended Offset and Gain Correction

For bi-directional current applications, the steps below are recommended for users trying to perform the best error correction of gain and offset.

1. Apply a known current value (A_1) and measure voltage output (V_1)
2. Apply a “second current value” (A_2) and measure the voltage output (V_2)
3. Calculate the slope using the following equation.

It is recommended that the applied currents A_1 and A_2 are the absolute maximum and minimum operating current the sensor will see during its normal operations.

Also, $A_1 = -A_2$ for bi-directional current sensing.

$$a = \frac{V_1 - V_2}{A_1 - A_2} \qquad b = \frac{V_1 + V_2}{2}$$

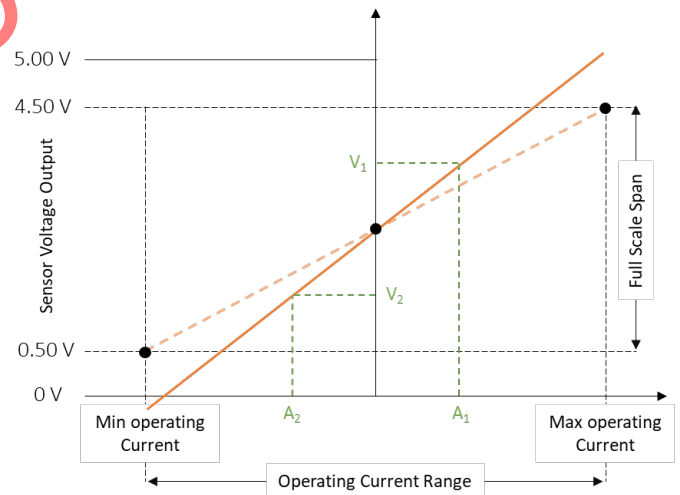

Figure 13. Gain Calibration

Both calculated coefficients “a” and “b” are then used to calculate the current:

$$Current = \frac{Voltage - b}{a}$$

Applications Information

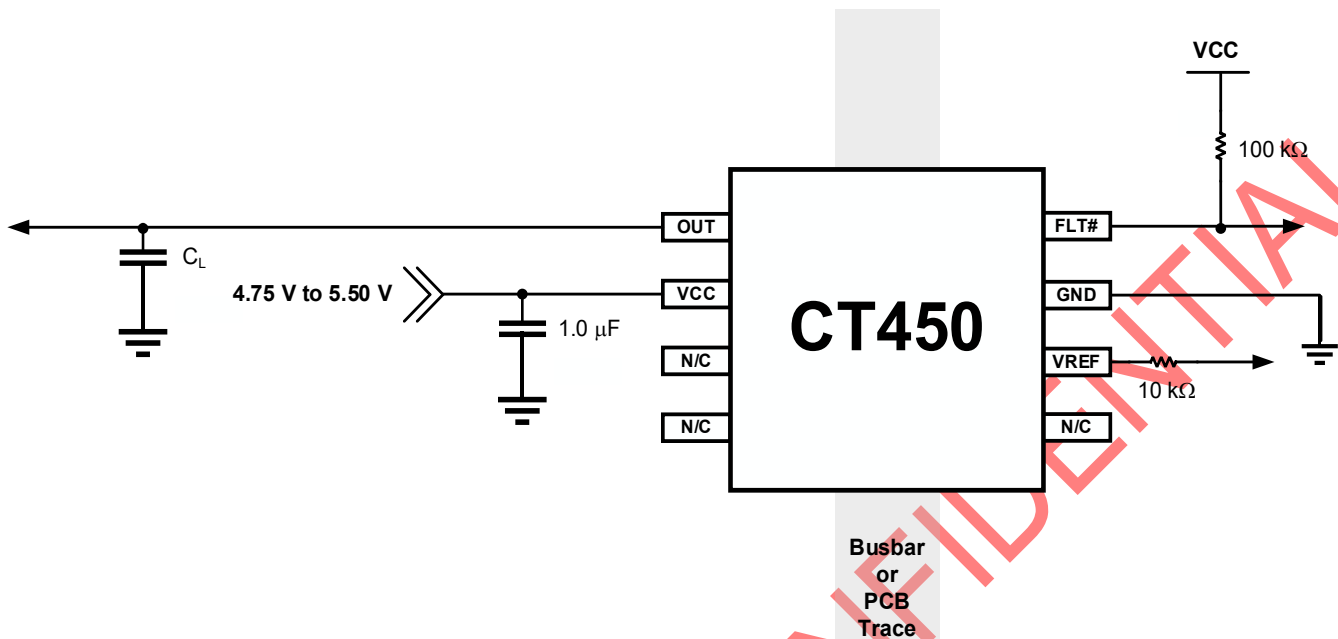

Figure 14. Application Diagram of CT450 Sensing Current of Busbar or PCB Trace Underneath It

Application

The CT450 is an integrated contactless current sensor that can be used in many applications from measuring current in solar inverters and other high-current applications. The chip outputs to a microcontroller a simple linear analog output voltage which corresponds to a magnetic field (current) measurement value. A second output called FLT# alerts the host system to any fault event that may occur in the CT450. Figure 14 is an application diagram of how CT450 would be implemented in a system.

It is designed to support an operating voltage range of 4.75 V to 5.50 V, but it is ideal to use a 5.00 V power supply where the output tolerance is less than $\pm 5\%$.

Current Sensing

The CT450 can sense and therefore measure the current by either placing a current-carrying busbar above or under the device. The busbar should be placed along the length of the package for the CT450 to measure the current. The chip is also sensitive enough to measure the current from a PCB trace that is routed underneath it. The magnetic sensitivity for the CT450 is approximately $40 \mu\text{T}/\text{A}$.

Bypass Capacitor

A single $1.0 \mu\text{F}$ capacitor is needed for the VCC pin to reduce the noise from the power supply and other circuits. This capacitor should be placed as close as possible to the CT450 to minimize inductance and resistance between the two devices.

FLT# and VREF Resistors

For the CT450, the FLT# pin is an open drain output. It requires a pull-up resistor value of $100 \text{ k}\Omega$ to be connected from the pin to VCC.

In designs where the VREF pin is used, a $10 \text{ k}\Omega$ resistor must be connected as close to the pin as possible in series with a load.

If the FLT# and/or VREF pins are not needed in the application, then these pins should not be connected and be left floating.

TSSOP-8 Package Drawing and Dimensions

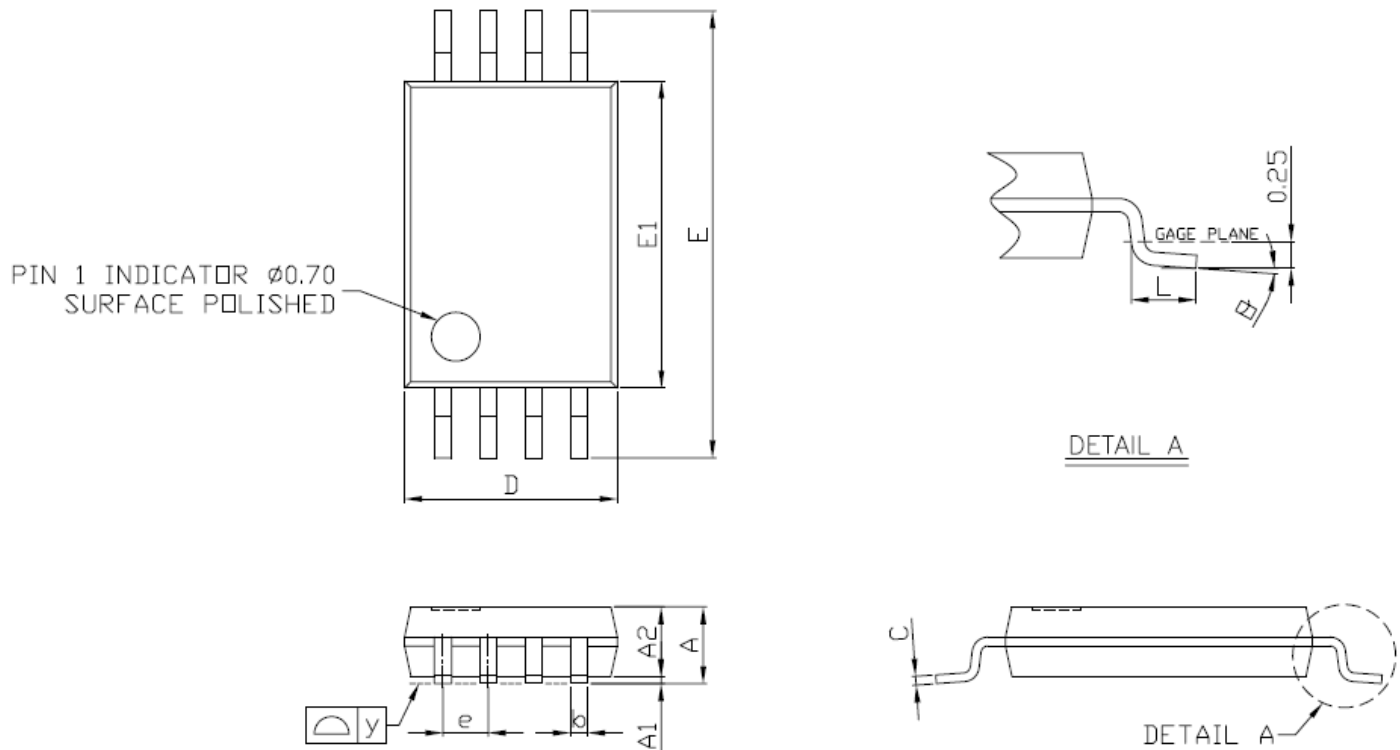

Figure 15. TSSOP-8 Package Drawing

Table 2. CT450 TSSOP-8 Package Dimensions

Symbol	Dimensions in Millimeters (mm)		
	Min.	Typ.	Max.
A	1.05	1.10	1.20
A1	0.05	0.10	0.15
A2	-	1.00	1.05
b	0.25	-	0.30
C	-	0.127	-
D	2.90	3.05	3.10
E	6.20	6.40	6.60
E1	4.30	4.40	4.50
e	-	0.65	-
L	0.50	0.60	0.70
y	-	-	0.076
θ	0°	4°	8°

Crocus Technology provides package drawings as a service to customers considering or planning to use Crocus products in their designs. Drawings may change without notice. Please note the revision and date of the data sheet and contact a Crocus Technology representative to verify or obtain the most recent version. The package specifications do not expand the terms of Crocus Technology's worldwide terms and conditions, specifically the warranty therein, which covers Crocus Technology's products.

TSSOP-8 Tape & Pocket Drawing and Dimensions

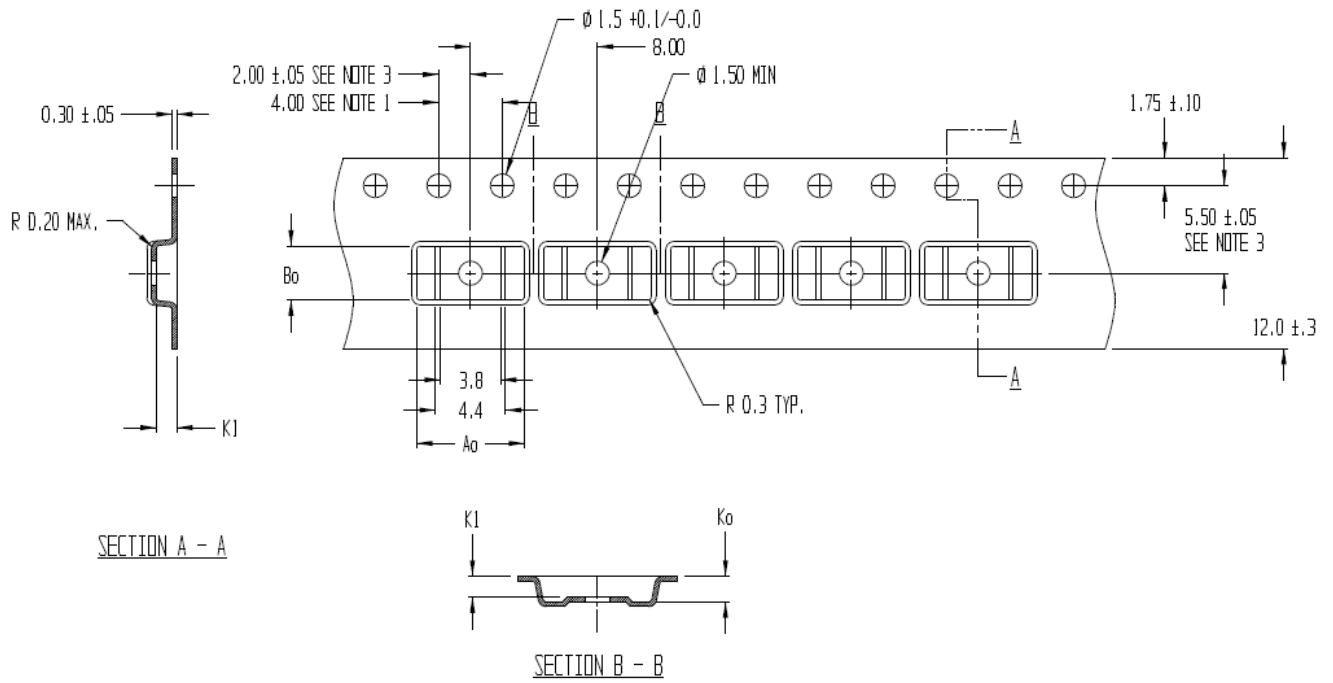

NOTES:

1. 10 SPROCKET HOLE PITCH CUMULATIVE TOLERANCE ± 0.2
2. CAMBER IN COMPLIANCE WITH EIA 481
3. POCKET POSITION RELATIVE TO SPROCKET HOLE MEASURED AS TRUE POSITION OF POCKET, NOT POCKET HOLE

$A_o = 6.80$
 $B_o = 3.40$
 $K_o = 1.60$
 $K_1 = 1.30$

Figure 16. TSSOP-8 Tape and Pocket Drawings

PRELIMINARY

Package Information

Table 3. CT450 Package Information

Part Number	Package Type	# of Leads	Package Quantity	Lead Finish	Eco Plan ⁽¹⁾	MSL Rating ⁽²⁾	Operating Temperature ⁽³⁾	Device Marking
CT450-E08DRTS08	TSSOP	8	3,000	Sn	Green & RoHS	1	-40°C to +85°C	CT450 E08DR
CT450-H08DRTS08	TSSOP	8	3,000	Sn	Green & RoHS	1	-40°C to +125°C	CT450 H08DR
CT450-E08MRTS08	TSSOP	8	3,000	Sn	Green & RoHS	1	-40°C to +85°C	CT450 E08MR
CT450-H08MRTS08	TSSOP	8	3,000	Sn	Green & RoHS	1	-40°C to +125°C	CT450 H08MR
CT450-E12DRTS08	TSSOP	8	3,000	Sn	Green & RoHS	1	-40°C to +85°C	CT450 E12DR
CT450-H12DRTS08	TSSOP	8	3,000	Sn	Green & RoHS	1	-40°C to +125°C	CT450 H12DR
CT450-E12MRTS08	TSSOP	8	3,000	Sn	Green & RoHS	1	-40°C to +85°C	CT450 E12MR
CT450-H12MRTS08	TSSOP	8	3,000	Sn	Green & RoHS	1	-40°C to +125°C	CT450 H12MR
CT450-E20DRTS08	TSSOP	8	3,000	Sn	Green & RoHS	1	-40°C to +85°C	CT450 E20DR
CT450-H20DRTS08	TSSOP	8	3,000	Sn	Green & RoHS	1	-40°C to +125°C	CT450 H20DR
CT450-E20MRTS08	TSSOP	8	3,000	Sn	Green & RoHS	1	-40°C to +85°C	CT450 E20MR
CT450-H20MRTS08	TSSOP	8	3,000	Sn	Green & RoHS	1	-40°C to +125°C	CT450 H20MR

- (1) RoHS is defined as semiconductor products that are compliant to the current EU RoHS requirements. It also will meet the requirement that RoHS substances do not exceed 0.1% by weight in homogeneous materials. Green is defined as the content of Chlorine (Cl), Bromine (Br) and Antimony Trioxide based flame retardants satisfy JS709B low halogen requirements of $\leq 1,000$ ppm.
- (2) MSL Rating = Moisture Sensitivity Level Rating as defined by JEDEC standard classifications.
- (3) Package will withstand ambient temperature range of -40°C to +125°C and storage temperature range of -65°C to +150°C.

Disclaimer: The contents of this document are provided for informational purposes only. CROCUS TECHNOLOGY, INC. AND CROCUS TECHNOLOGY SA (COLLECTIVELY "CROCUS") MAKE NO REPRESENTATIONS OR WARRANTY OF ANY KIND, EXPRESS OR IMPLIED, WITH RESPECT TO THE ACCURACY OR COMPLETENESS OF THE CONTENTS HEREIN, INCLUDING, BUT NOT LIMITED TO, THE IMPLIED WARRANTIES OF MERCHANTABILITY AND FITNESS FOR A PARTICULAR PURPOSE. Crocus reserves the right to make changes to the specifications and product descriptions, and/or to discontinue or make changes to its products at any time without notice. Crocus's products have not been designed, tested, or manufactured for use and should not be used in applications where the failure, malfunction or inaccuracy of the Products carries a risk of death or serious bodily injury or damage to tangible property, including, but not limited to, life support systems, nuclear facilities, military, aircraft navigation or communication, emergency systems, harsh environments, or other applications with a similar degree of potential hazard.

Product Status Definition

Data Sheet Identification	Product Status	Definition
Objective	Proposed New Product Idea or In Development	Data sheet contains design target specifications and are subject to change without notice at any time.
Preliminary	First Production	Data sheet contains preliminary specifications obtained by measurements of early samples. Follow-on data will be published at a later date as more test data is acquired. Crocus reserves the right to make changes to the data sheet at any time.
None	Full Production	Data sheet contains final specifications for all parameters. Crocus reserves the right to make changes to the data sheet at any time.
Obsolete	Not in Production	Data sheet for a product that is no longer in production at Crocus. It is for reference only.