

**THERMISTOR SPECIFICATIONS**

1) SCOPE

This specifications define rating, dimensions, insulation, climatic sequence and mechanical characteristics for AT type thermistor.

2) PART NO. : **102AT-2**

3) RATING

3-1) Rated zero-power resistance.  $R_{25}$  : 1 k $\Omega$   $\pm$  1 % (at 25  $^{\circ}$ C )

3-2) B value.  $B_{25/85}$  : 3,100 K  $\pm$  1 %

\* The B value is calculated using the zero-power resistance values measured at 25 $^{\circ}$ C and 85 $^{\circ}$ C.

3-3) Dissipation factor. : Approx. 2 mW/ $^{\circ}$ C (in air)

3-4) Thermal time constant. : Approx. 15 s (in air)

3-5) Maximum power rating. : 10 mW (at 25 $^{\circ}$ C)

3-6) Category temperature range : -50 ~ 90  $^{\circ}$ C

(= Operating temperature range)

4) DIMENSIONS

UNIT:[mm]

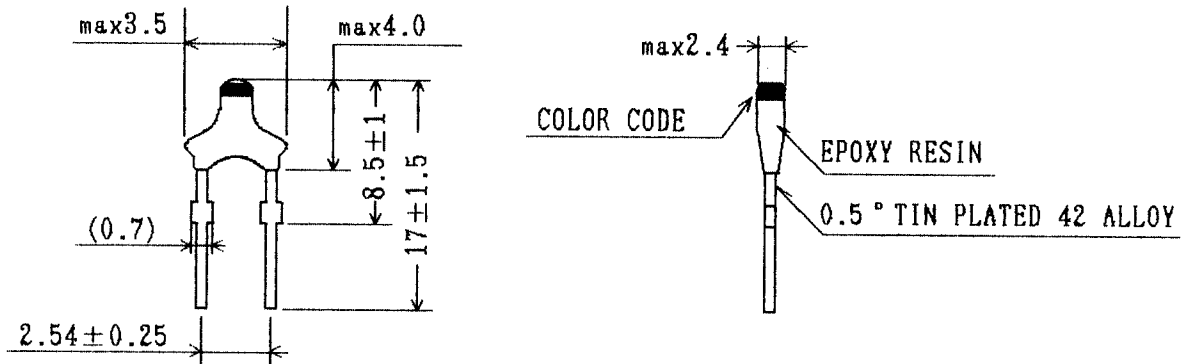

COLOR CODE : Black (This indicates 102AT-2 thermistor.)

Spec.NO.: STANDARD-01		Note		REVISION	
Date: NOV.13,1992				A	
Approved	Checked	Drawn			
		K.KUMADA	B		
			C		

AT-01-

1/3

NSSP-AT-200

## 5) INSULATION

### 5-1) Insulation resistance

Insulation resistance of the test samples shall be over 100 MΩ when it is measured at DC 500V between coated area and lead wires.

## 6) CLIMATIC SEQUENCE

### 6-1) Dry heat

After the test samples were exposed in air at 90 °C for 1,000 hours, the change ratio of the rated zero-power resistance shall be within ± 1% of the initial value.

### 6-2) Damp heat

After the test samples were exposed in the humidity of 95% at 70°C for 1,000 hours, the change ratio of the rated zero-power resistance shall be within ± 1% of the initial value.

### 6-3) Cold

After the test samples were exposed in air at -55°C for 1,000 hours, the change ratio of the rated zero-power resistance shall be within ±1% of the initial value.

### 6-4) Humidity load

After DC 1mA current was applied to the test samples in the temperature of 70°C and the humidity of 95% for 1,000 hours, the change ratio of the rated zero-power resistance shall be within ± 1% of the initial value.

### 6-5) Change of temperature

One cycle of the change of temperature shall be carried out in the order of the following conditions.

- Room ambient temperature. (Initial value)
- At -30°C, for 30 minutes.
- Room ambient temperature, for 3 minutes.
- At + 90°C, for 30 minutes.
- Room ambient temperature. for 3 minutes.

After 100 cycles of change of temperature, the change ratio of the rated zero-power resistance shall be within ±1% of the initial value.

---

AT THERMISTOR

STANDARD

AT-00-10

2/3

NSSP-AT-120

## 7) MECHANICAL CHARACTERISTICS

### 7-1) Robustness of terminations

Ua: Tensile

After 0.2 kgf loading weight for 3 seconds was applied to the wire terminations, there shall be no visible damage.

### 7-2) Free fall

After one time natural fall to a maple board from 1 m high, there shall be no visible damage.

### 7-3) Resistance to soldering heat

After lead wire of the test samples were dipped one time within 8.5 mm from end of lead wire in solder bath at  $260^{\circ}\text{C} \pm 10^{\circ}\text{C}$  for  $10 \pm 0.5$  seconds, the change ratio of the rated zero-power resistance shall be within  $\pm 1\%$  of the initial value.

---

AT THERMISTOR

STANDARD

AT-00-\*\*

3/3

NSSP-AT-130