

# Specification for Approval

**PRODUCT NAME:** RGS11096096FR013  
**PRODUCT NO.:** 90L9927801000

<b>CUSTOMER</b>
<b>APPROVED BY</b>
<b>DATE:</b>

<b>RITDISPLAY CORP. APPROVED</b>

## REVISION RECORD

REV.	REVISION DESCRIPTION	REV. DATE	REMARK
X01	INITIAL RELEASE	2013. 01. 25	
X02	<ul style="list-style-type: none"><li>■ Add the information of module weight</li><li>■ Add operating conditions for different luminance</li><li>■ Add panel electrical specifications</li><li>■ Add application circuit</li></ul>	2013. 05. 08	Page 5, 6, 7, 8, 9, 10 & 17
A01	<ul style="list-style-type: none"><li>■ Transfer from X version</li><li>■ Add the packing specification</li></ul>	2013. 10. 16	Page 21
A02	<ul style="list-style-type: none"><li>■ Add appendix of precautions for using the OLED module</li></ul>	2014. 03. 31	Page 26~35

## CONTENTS

ITEM	PAGE
<b>1. SCOPE</b>	4
<b>2. WARRANTY</b>	4
<b>3. FEATURES</b>	4
<b>4. MECHANICAL DATA</b>	5
<b>5. MAXIMUM RATINGS</b>	6
<b>6. ELECTRICAL CHARACTERISTICS</b>	8
6.1 D.C ELECTRICAL CHARACTERISTICS	
6.2 ELECTRO-OPTICAL CHARACTERISTICS	
<b>7. INTERFACE</b>	11
7.1 FUNCTION BLOCK DIAGRAM	
7.2 PANEL LAYOUT DIAGRAM	
7.3 PIN ASSIGNMENTS	
7.4 GRAPHIC DISPLAY DATA RAM ADDRESS MAP	
7.5 INTERFACE TIMING CHART	
<b>8. POWER ON / OFF SEQUENCE &amp; APPLICATION CIRCUIT</b>	16
8.1 POWER ON / OFF SEQUENCE	
8.2 APPLICATION CIRCUIT	
8.3 COMMAND TABLE	
<b>9. RELIABILITY TEST CONDITIONS</b>	18
<b>10. EXTERNAL DIMENSION</b>	19
<b>11. PACKING SPECIFICATION</b>	21
<b>12. APPENDIXES</b>	22

## **1. SCOPE**

The purpose of this specification is to define the general provisions and quality requirements that apply to the supply of display cells manufactured by RiTdisplay. This document, together with the Module Ass'y Drawing, is the highest-level specification for this product. It describes the product, identifies supporting documents and contains specifications.

## **2. WARRANTY**

RiTdisplay warrants that the products delivered pursuant to this specification (or order) will conform to the agreed specifications for twelve (12) months from the shipping date ("Warranty Period"). RiTdisplay is obligated to repair or replace the products which are found to be defective or inconsistent with the specifications during the Warranty Period without charge, on condition that the products are stored or used as the conditions specified in the specifications. Nevertheless, RiTdisplay is not obligated to repair or replace the products without charge if the defects or inconsistency are caused by the force majeure or the reckless behaviors of the customer.

After the Warranty Period, all repairs or replacements of the products are subject to charge.

## **3. FEATURES**

- Small molecular organic light emitting diode.
- Color : 262K color and 65K colors
- Panel matrix : 96x96
- Driver IC : SSD1351
- Excellent quick response time.
- Extremely thin thickness for best mechanism design : 1.227mm
- High contrast : 2000:1
- Wide viewing angle : 160°
- 8/16-bit 8080-series Parallel Interface, Serial Peripheral Interface.
- Wide range of operating temperature : -40 to 70 °C
- Anti-glare polarizer.

#### 4. MECHANICAL DATA

NO	ITEM	SPECIFICATION	UNIT
1	Dot Matrix	96 (W) x (RxGxB) x 96 (H)	dot
2	Dot Size	0.045 (W) x 0.19 (H)	mm <sup>2</sup>
3	Dot Pitch	0.07 (W) x 0.21 (H)	mm <sup>2</sup>
4	Aperture Rate	58	%
5	Active Area	20.135 (W) x 20.14 (H)	mm <sup>2</sup>
6	Panel Size	25.8 (W) x 30.1 (H)	mm <sup>2</sup>
7	Panel Thickness	1.02 ± 0.1	mm
8	Module Size	25.8 (W) x 48.1 (H) x 1.227 (D)	mm <sup>3</sup>
9	Diagonal A/A size	1.12	inch
10	Module Weight	1.89 ± 10%	gram

\* Panel thickness includes substrate glass, cover glass and UV glue thickness.

## 5. MAXIMUM RATINGS

ITEM	MIN	MAX	UNIT	Condition	Remark
Supply Voltage ( $V_{Cl}$ )	-0.3	4	V	$T_a = 25^\circ\text{C}$	IC maximum rating
Supply Voltage ( $V_{cc}$ )	10	21	V	$T_a = 25^\circ\text{C}$	IC maximum rating
Operating Temp.	-40	70	$^\circ\text{C}$		
Storage Temp	-40	85	$^\circ\text{C}$		
Humidity	-	85	%		
Life Time	10,000	-	Hrs	100 $\text{cd}/\text{m}^2$ , 50% checkerboard	Note (1)
Life Time	13,000	-	Hrs	80 $\text{cd}/\text{m}^2$ , 50% checkerboard	Note (2)
Life Time	16,000	-	Hrs	60 $\text{cd}/\text{m}^2$ , 50% checkerboard	Note (3)

Note:

(A) Under  $V_{cc} = 15\text{V}$ ,  $T_a = 25^\circ\text{C}$ , 50% RH.

(B) Life time is defined the amount of time when the luminance has decayed to less than 50% of the initial measured luminance.

(1) Setting of 100  $\text{cd}/\text{m}^2$  :

- Master contrast setting : 0x0e
- Blue contrast setting : 0x75
- Green contrast setting : 0x42
- Red contrast setting : 0x49
- Frame rate : 105Hz
- Duty setting : 1/96

(2) Setting of 80  $\text{cd}/\text{m}^2$  :

- Master contrast setting : 0x0c
- Blue contrast setting : 0x6b
- Green contrast setting : 0x3c
- Red contrast setting : 0x42
- Frame rate : 105Hz
- Duty setting : 1/96

(3) Setting of 60 cd/m<sup>2</sup> :

- Master contrast setting : 0x09
- Blue contrast setting : 0x68
- Green contrast setting : 0x3b
- Red contrast setting : 0x40
- Frame rate : 105Hz
- Duty setting : 1/96

## 6. ELECTRICAL CHARACTERISTICS

### 6.1 D.C ELECTRICAL CHARACTERISTICS

SYMBOL	PARAMETERS	TEST CONDITION	MIN	TYP	MAX	UNIT
$V_{CC}$	Analog power supply (for OLED panel)		14.5	15	15.5	V
$V_{CI}$	Digital power supply		2.4	2.8	3.5	V
$V_{DDIO}$	I/O voltage power supply		1.65	1.8	$V_{CI}$	V
$I_{DD}$	$V_{CI} = V_{DDIO} = 3.5V$ , $V_{CC} = 16V$ , External $V_{DD} = 2.6V$ , Display ON, No panel attached, contrast = FF			170	190	$\mu A$
$I_{DDIO}$	$V_{CI} = V_{DDIO} = 3.5V$ , $V_{CC} = 16V$ , Display ON, No panel attached, contrast = FF	External VDD = 2.6V		0.5	10	$\mu A$
		Internal VDD		0.5	10	$\mu A$
$I_{CI}$	$V_{CI} = V_{DDIO} = 3.5V$ , $V_{CC} = 16V$ , Display ON, No panel attached, contrast = FF	External VDD = 2.6V	-	60	70	$\mu A$
		Internal VDD		255	280	$\mu A$
$I_{CC}$	$V_{CI} = V_{DDIO} = 3.5V$ , $V_{CC} = 16V$ , Display ON, No panel attached, contrast = FF	External VDD = 2.6V	-	1.15	1.26	mA
		Internal VDD		1.15	1.26	mA
$V_{IH}$	Hi logic input level		0.8* $V_{DDIO}$	-	$V_{DDIO}$	V
$V_{IL}$	Low logic input level		0	-	0.2* $V_{DDIO}$	V
$V_{OH}$	Hi logic output level		0.9* $V_{DDIO}$	-	$V_{DDIO}$	V
$V_{OL}$	Low logic output level		0	-	0.1* $V_{DDIO}$	V
$I_{SEG}$	Segment Output Current Setting $V_{CC} = 16V$ at $I_{REF} =$ 12.5 $\mu A$	Contrast=FF	-	200	-	$\mu A$
		Contrast=7F	-	100	-	$\mu A$
		Contrast=3F	-	50	-	$\mu A$



## 6.2 ELECTRO-OPTICAL CHARACTERISTICS

### PANEL ELECTRICAL SPECIFICATIONS

PARAMETER	MIN	TYP.	MAX	UNITS	COMMENTS
Normal mode current		16	18	mA	All pixels on (1)
Standby mode current		6.5	8.5	mA	Standby mode 10% pixels on (2)
Normal mode power consumption		240	270	mW	All pixels on (1)
Standby mode power consumption		97.5	127.5	mW	Standby mode 10% pixels on (2)
Normal mode Luminance	60	80		cd/m <sup>2</sup>	Display Average
Standby mode Luminance		20		cd/m <sup>2</sup>	
CIE <sub>x</sub> (White)	0.24	0.28	0.32		x, y (CIE 1931)
CIE <sub>y</sub> (White)	0.28	0.32	0.36		
CIE <sub>x</sub> (Red)	0.62	0.66	0.70		
CIE <sub>y</sub> (Red)	0.29	0.33	0.37		
CIE <sub>x</sub> (Green)	0.26	0.30	0.34		
CIE <sub>y</sub> (Green)	0.59	0.63	0.67		
CIE <sub>x</sub> (Blue)	0.10	0.14	0.18		
CIE <sub>y</sub> (Blue)	0.14	0.18	0.22		
Dark Room Contrast	2000:1				
Viewing Angle	160			degree	
Response Time		10		μs	

(1) Normal mode condition :

- Driving Voltage : 15V
- Master contrast setting : 0x0c
- Blue contrast setting : 0x6b
- Green contrast setting : 0x3c
- Red contrast setting : 0x42
- Frame rate : 105Hz
- Duty setting : 1/96

(2) Standby mode condition :

- Driving Voltage : 15V
- Master contrast setting : 0x04
- Blue contrast setting : 0x61
- Green contrast setting : 0x38
- Red contrast setting : 0x3b
- Frame rate : 105Hz
- Duty setting : 1/96

## 7. INTERFACE

### 7.1 FUNCTION BLOCK DIAGRAM

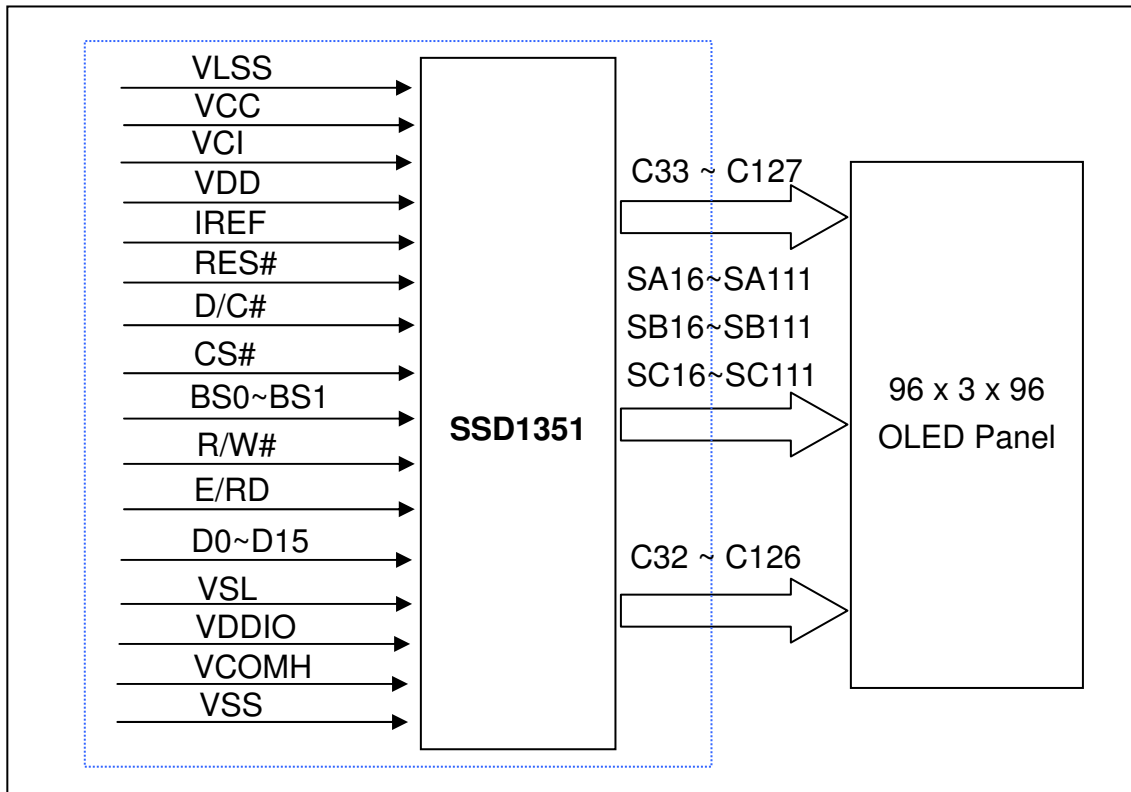

### 7.2 PANEL LAYOUT DIAGRAM

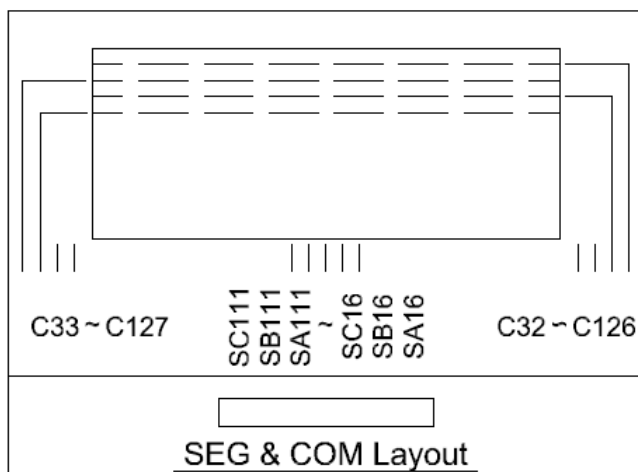

### 7.3 PIN ASSIGNMENTS

PIN NO	PIN NAME	DESCRIPTION
1	NC	Not Connected.
2	VLSS	Analog system ground pin.
3	VCC	Power supply for panel driving voltage.
4	VCI	Low voltage power supply VCI must always be equal to or higher than VDD and VDDIO.
5	VDD	Power supply pin for core logic operation.
6	IREF	A resistor should be connected between this pin and VSS.
7	RES#	This pin is reset signal input.
8	D/C#	This pin is Data/Command control pin connecting to the MCU.
9	CS#	This pin is the chip select input connecting to the MCU.
10	BS1	MCU bus interface selection pins.
11	BS0	
12	R/W#	This pin is read / write control input pin connecting to the MCU interface.
13	E/RD#	This pin is MCU interface input.
		When 8080 interface mode is selected, this pin receives the Read (RD#) signal. Read operation is initiated when this pin is pulled LOW and the chip is selected.
		When serial interface is selected, this pin E(RD#) must be connected to VSS.
14	D0	These pins are bi-directional data bus connecting to the MCU data bus. Unused pins are recommended to tie LOW. (Except for D2 pin in SPI mode)
15	D1	
16	D2	
17	D3	
18	D4	
19	D5	
20	D6	
21	D7	
22	D8	
23	D9	
24	D10	
25	D11	
26	D12	
27	D13	

28	D14	
29	D15	
30	VSL	This is segment voltage reference pin. External VSL is set as default. This pin has to connect with resistor and diode to ground. (Details depend on application)
31	VDDIO	Power supply for interface logic level.
32	VCOMH	A capacitor should be connected between this pin and VSS.
33	VCC	Power supply for panel driving voltage.
34	VSS	Ground pin

### 7.4 GRAPHIC DISPLAY DATA RAM ADDRESS MAP

The GDDRAM is a bit mapped static RAM holding the pattern to be displayed. The RAM size is 128 x 128 x 18bits. For mechanical flexibility, re-mapping on both Segment and Common outputs can be selected by software. Each pixel has 18-bit data. Each sub-pixels for color A, B and C have 6 bits. The arrangement of data pixel in graphic display data RAM is shown below.

262k Color Depth Graphic Display Data RAM Structure

Segment Address	Normal	0			1			2	.....	.....	126	127			
	Remapped	127			126			125	.....	.....	1	0			
Color		A	B	C	A	B	C	A	.....	.....	C	A	B	C	
Common Address	Data	A5	B5	C5	A5	B5	C5	A5	.....	.....	C5	A5	B5	C5	
	Format	A4	B4	C4	A4	B4	C4	A4	.....	.....	C4	A4	B4	C4	
		A3	B3	C3	A3	B3	C3	A3	.....	.....	C3	A3	B3	C3	
		A2	B2	C2	A2	B2	C2	A2	.....	.....	C2	A2	B2	C2	
		A1	B1	C1	A1	B1	C1	A1	.....	.....	C1	A1	B1	C1	
		A0	B0	C0	A0	B0	C0	A0	.....	.....	C0	A0	B0	C0	
Normal	Remapped													Common output	
0	127	6	6	6	6	6	6	6	.....	.....	6	6	6	6	COM0
1	126	6	6	6	6	6	6	6	.....	.....	6	6	6	6	COM1
2	125	6	6	6	6	6	6	6	.....	.....	6	6	6	6	COM2
3	124	6	6	6	6	6	6	6	.....	.....	6	6	6	6	COM3
4	123	6	6	6	6	6	6	6	.....	.....	6	6	6	6	COM4
5	122	6	6	6	6	6	6	6	.....	.....	6	6	6	6	COM5
6	121	6	6	no of bits in this cell			6	6	.....	.....	6	6	6	6	COM6
7	120								.....	.....	6	6	6	6	COM7
:	:	:	:	:	:	:	:	:	.....	.....	:	:	:	:	:
:	:	:	:	:	:	:	:	:	.....	.....	:	:	:	:	:
:	:	:	:	:	:	:	:	:	.....	.....	:	:	:	:	:
123	4	6	6	6	6	6	6	6	.....	.....	6	6	6	6	:
124	3	6	6	6	6	6	6	6	.....	.....	6	6	6	6	COM124
125	2	6	6	6	6	6	6	6	.....	.....	6	6	6	6	COM125
126	1	6	6	6	6	6	6	6	.....	.....	6	6	6	6	COM126
127	0	6	6	6	6	6	6	6	.....	.....	6	6	6	6	COM127

SEGoutput	SA0	SB0	SC0	SA1	SB1	SC1	SA2	.....	.....	SC126	SA127	SB127	SC127
-----------	-----	-----	-----	-----	-----	-----	-----	-------	-------	-------	-------	-------	-------

## 7.5 INTERFACE TIMING CHART

8080-Series MCU Parallel Interface Timing Characteristics

( $V_{DD} - V_{SS} = 2.4$  to  $2.6V$ ,  $V_{DDIO} = 1.65V$ ,  $V_{CI} = 2.8V$ ,  $T_A = 25^\circ C$ )

Symbol	Parameter	Min	Typ	Max	Unit
$t_{CYCLE}$	Clock Cycle Time	300	-	-	ns
$t_{AS}$	Address Setup Time	10	-	-	ns
$t_{AH}$	Address Hold Time	0	-	-	ns
$t_{DSW}$	Write Data Setup Time	40	-	-	ns
$t_{DHW}$	Write Data Hold Time	7	-	-	ns
$t_{DHR}$	Read Data Hold Time	20	-	-	ns
$t_{OH}$	Output Disable Time	-	-	70	ns
$t_{ACC}$	Access Time	-	-	140	ns
$t_{PWL R}$	Read Low Time	150	-	-	ns
$t_{PWL W}$	Write Low Time	60	-	-	ns
$t_{PWH R}$	Read High Time	60	-	-	ns
$t_{PWH W}$	Write High Time	60	-	-	ns
$t_R$	Rise Time	-	-	15	ns
$t_F$	Fall Time	-	-	15	ns
$t_{CS}$	Chip select setup time	0	-	-	ns
$t_{CSH}$	Chip select hold time to read signal	0	-	-	ns
$t_{CSF}$	Chip select hold time	20	-	-	ns

8080-series MCU parallel interface characteristics

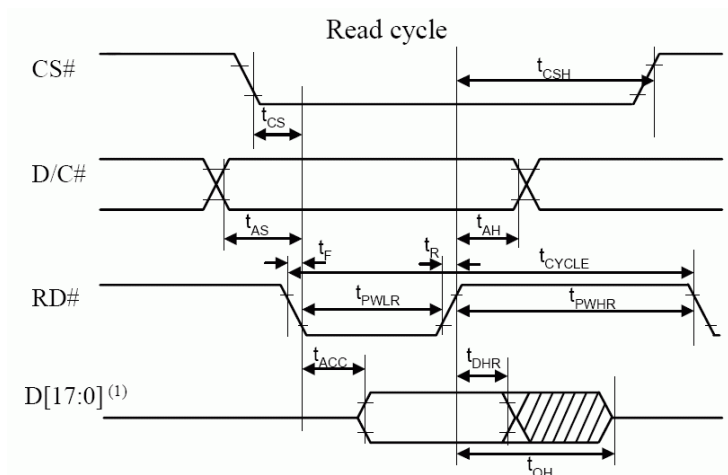
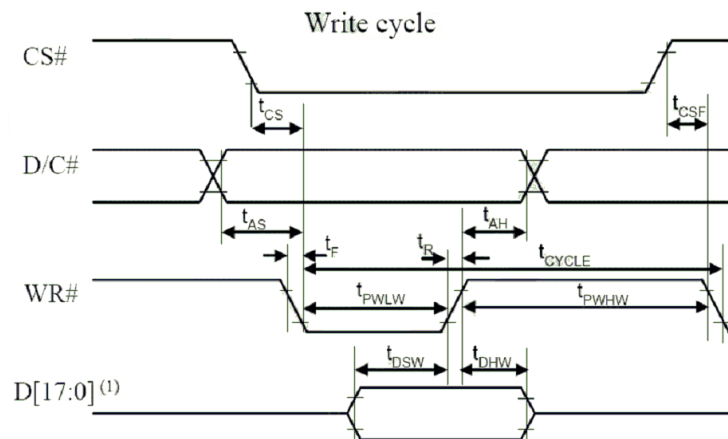

### Note

(1) when 8 bit used: D[7:0] instead; when 16 bit used: [15:0] instead; when 18 bit used: D[17:0] instead.

## 8. POWER ON / OFF SEQUENCE & APPLICATION CIRCUIT

### 8.1 POWER ON / OFF SEQUENCE

The following figures illustrate the recommended power ON and power OFF sequence of SSD1351

#### Power ON sequence:

1. Power ON  $V_{CI}$ ,  $V_{DDIO}$ .
2. After  $V_{CI}$ ,  $V_{DDIO}$  become stable, set wait time at least 1ms ( $t_0$ ) for internal  $V_{DD}$  become stable. Then set RES# pin LOW (logic low) for at least 2us ( $t_1$ )<sup>(4)</sup> and then HIGH (logic high).
3. After set RES# pin LOW (logic low), wait for at least 2us ( $t_2$ ). Then Power ON  $V_{CC}$ .<sup>(1)</sup>
4. After  $V_{CC}$  become stable, send command AFh for display ON. SEG/COM will be ON after 200ms( $t_{AF}$ ).

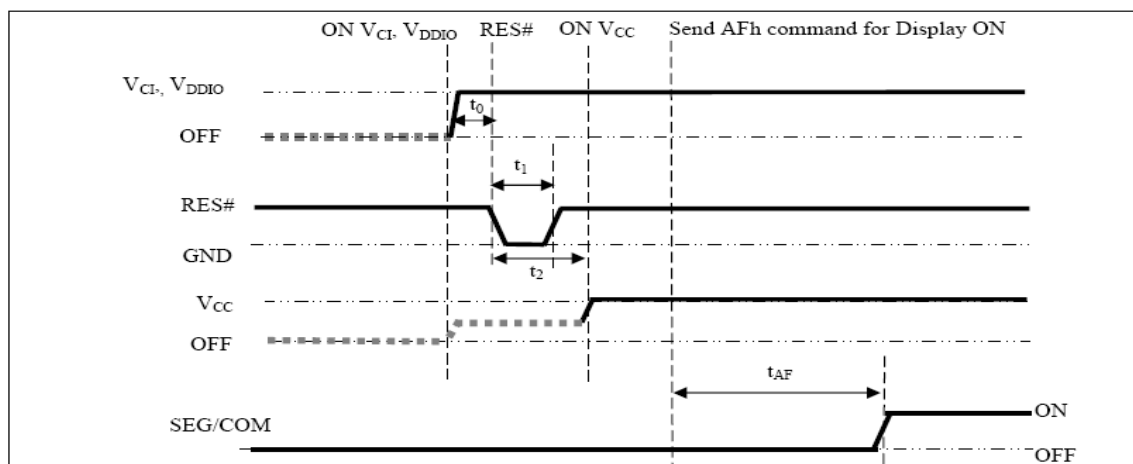

#### Power OFF sequence:

1. Send command AEh for display OFF.
2. Power OFF  $V_{CC}$ .<sup>(1), (2)</sup>
3. Wait for  $t_{OFF}$ . Power OFF  $V_{CI}$ ,  $V_{DDIO}$ . (where Minimum  $t_{OFF}$ =80ms<sup>(3)</sup>, Typical  $t_{OFF}$ =100ms)

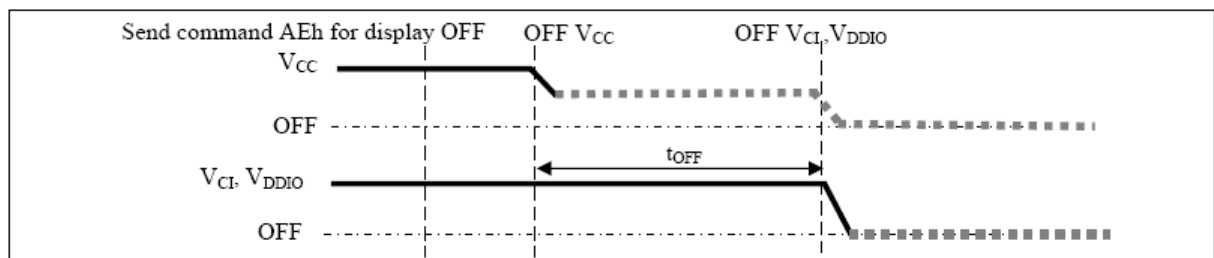

#### Note:

- (1) Since an ESD protection circuit is connected between  $V_{CI}$ ,  $V_{DDIO}$  and  $V_{CC}$ ,  $V_{CC}$  becomes lower than  $V_{CI}$  whenever  $V_{CI}$ ,  $V_{DDIO}$  is ON and  $V_{CC}$  is OFF as shown in the dotted line of  $V_{CC}$  in Figure
- (2)  $V_{CC}$  should be kept float (disable) when it is OFF.
- (3)  $V_{CI}$ ,  $V_{DDIO}$  should not be Power OFF before  $V_{CC}$  Power OFF.
- (4) The register values are reset after  $t_1$ .
- (5) Power pins ( $V_{CI}$ ,  $V_{DDIO}$  and  $V_{CC}$ ) can never be pulled to ground under any circumstance.



## 8.2 APPLICATION CIRCUIT

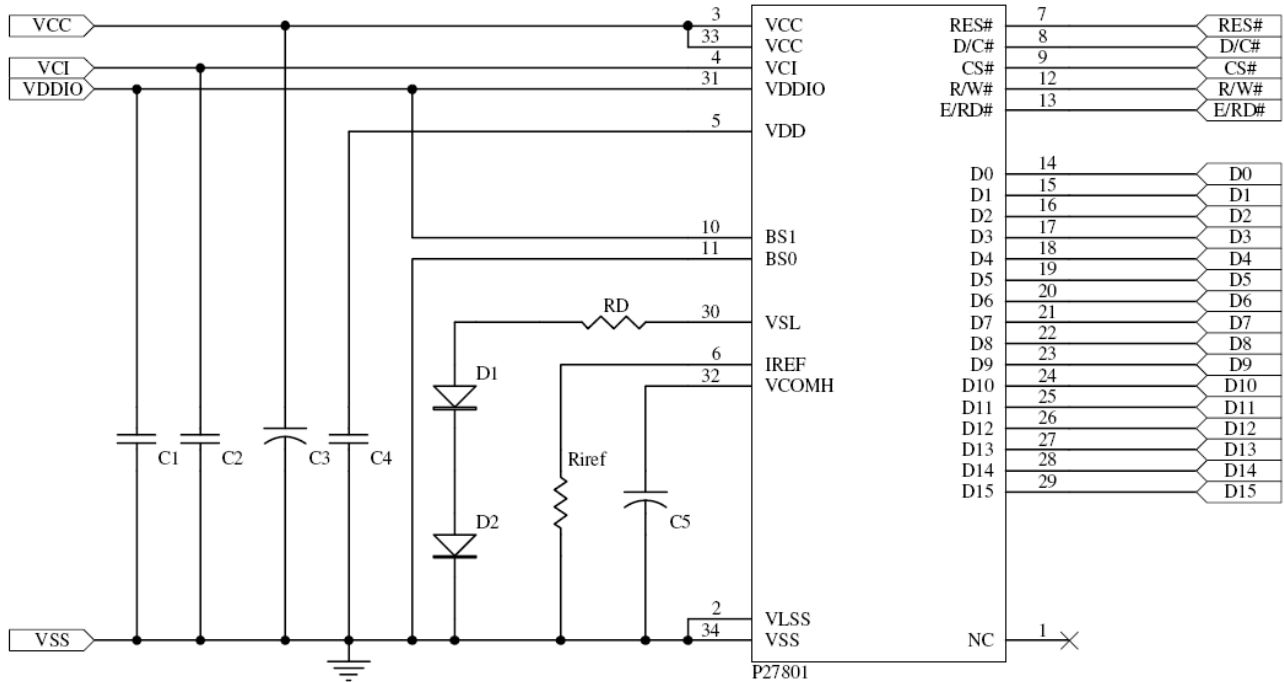

### Recommend components :

C1 、 C2 、 C4 : 1uF/16V(0805)

C3 、 C5 : 4.7uF/35V (Tantalum type) or VISHAY (572D475X0025A2T)

Riref : 1M ohm 1% (0603)

RD : 50 ohm 1/4W

D1 、 D2 : RB480K (ROHM)

**This circuit is designed for 16bit 8080 interface.**

## 8.3 COMMAND TABLE

Refer to SSD1351 IC Spec.

## 9. RELIABILITY TEST CONDITIONS

No.	Items	Specification	Quantity
1	High temp. (Non-operation)	85 °C, 240hrs	5
2	High temp. (Operation)	70 °C, 120hrs	5
3	Low temp. (Operation)	-40 °C, 120hrs	5
4	High temp. / High humidity (Operation)	65 °C, 90%RH, 96hrs	5
5	Thermal shock (Non-operation)	-40 °C ~85 °C (-40 °C /30min; transit /3min; 85 °C /30min; transit /3min) 1cycle: 66min, 20 cycles	5
6	Vibration	Frequency : 5~50HZ, 0.5G Scan rate : 1 oct/min Time : 2 hrs/axis Test axis : X, Y, Z	1 Carton
7	Drop	Height: 120cm Sequence : 1 angle 、 3 edges and 6 faces Cycles: 1	1 Carton
8	ESD (Non-operation)	Air discharge model, ±8kV, 10 times	5

### **Test and measurement conditions**

1. All measurements shall not be started until the specimens attain to temperature stability.
2. All-pixels-on is used as operation test pattern.
3. The degradation of Polarizer are ignored for item 1, 4 & 5.

### **Evaluation criteria**

1. The function test is OK.
2. No observable defects.
3. Luminance: > 50% of initial value.
4. Current consumption: within  $\pm$  50% of initial value.

## 10. EXTERNAL DIMENSION

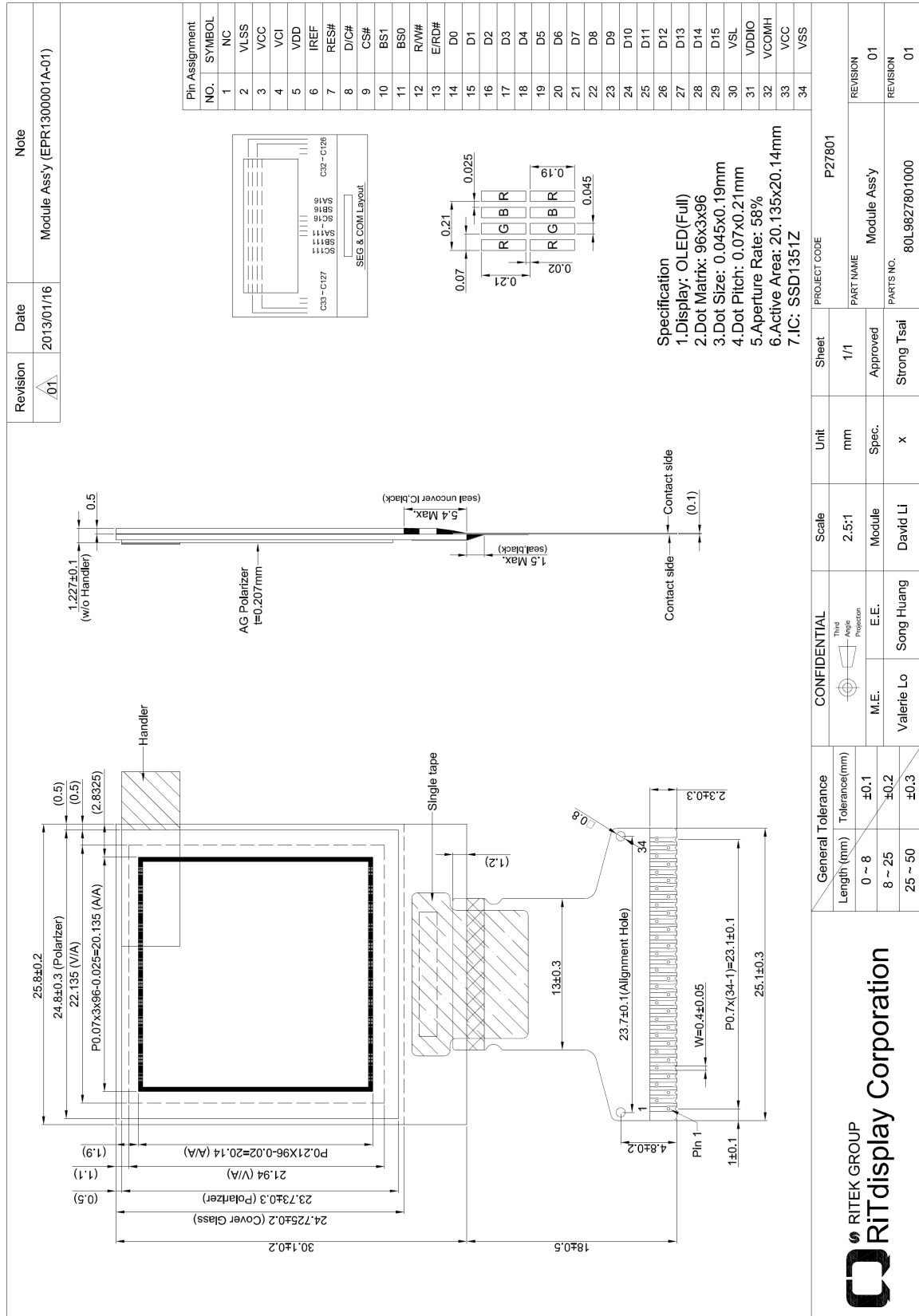

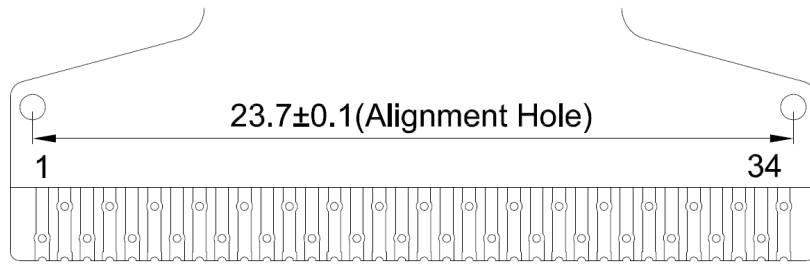

Suggested PCB mounting dimensions

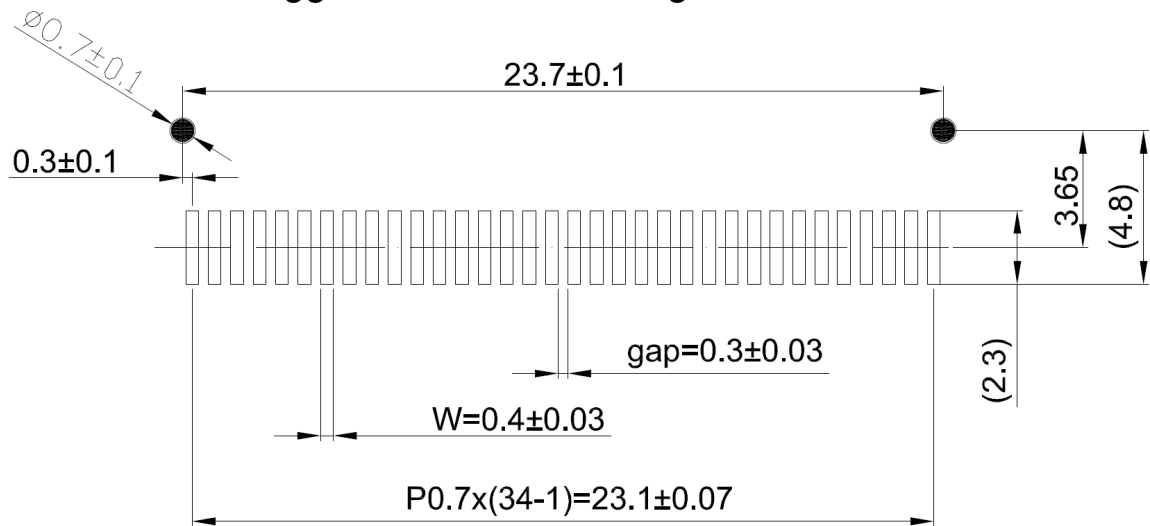

**11. PACKING SPECIFICATION**

Revision ▲.01	Date 2013/01/25	Note Packing Tray Instruction
------------------	--------------------	----------------------------------

80L9827801000  
Module Assy For P27801 x42 pcs

1

3010000003  
3G Silica Gel Desiccants  
5G 乾燥劑  
x 1 pcs(empty)

3

3010000005  
Tray =21 pcs  
Tape  
3208000125

4

30030000012  
Vacuum Bag ONY/LDPE  
真空包裝袋  
480x285x90

5

30030000016  
Antistatic Bubble bag 440x(350+450)mm  
抗靜電氣泡袋

6

30010000005  
Pizza Box 345x285x88,B corrugated

7

30000000009  
Carton 385x305x203mm

8

30060000000  
Label x1 pcs

9

30060000000  
Label x2 pcs

Vacuum packing : 4 sec  
抽真空 : 4 秒

ITEM	PART No.	DESC	QTY
1	90L9827801000		1
1	80L9827801000	Module Assy For P27801	1680
2	700P278011001	Tray 330x270x8.5 T:0.5mm PET P27801	42
3	3010000003	5G Silica Gel Desiccants	8
4	30030000012	Vacuum Bag ONY/LDPE 480x285x90	2
5	30030000016	Antistatic Bubble bag 440x(350+450)mm	2
6	30010000005	Pizza Box 345x285x88,B corrugated	2
7	30000000009	Carton 385x305x203mm	1
8	30060000000	Label	3
9	3208000125	Tape, W=48mm, L=910cm	

General Tolerance		CONFIDENTIAL		PROJECT CODE	
Length (mm)	Tolerance (mm)	M.I.E.	Third Angle Projection	PART NAME	P27801
0 ~ 8	±0.1			Packing Tray Instruction	VERSION
8 ~ 25	±0.2	Iven Lee	X	PARTS NO.	90L9827801000
25 ~ 50	±0.3	Kelly Hsu		Strong Tsai	VERSION
					01
					01

**RITEK GROUP**  
**RiTdisplay Corporation**

## **12. APPENDIXES**

### **APPENDIX 1: DEFINITIONS**

#### **A. DEFINITION OF CHROMATICITY COORDINATE**

The chromaticity coordinate is defined as the coordinate value on the CIE 1931 color chart for R, G, B, W.

#### **B. DEFINITION OF CONTRAST RATIO**

The contrast ratio is defined as the following formula:

$$\text{Contrast Ratio} = \frac{\text{Luminance of all pixels on measurement}}{\text{Luminance of all pixels off measurement}}$$

#### **C. DEFINITION OF RESPONSE TIME**

The definition of turn-on response time  $T_r$  is the time interval between a pixel reaching 10% of steady state luminance and 90% of steady state luminance. The definition of turn-off response time  $T_f$  is the time interval between a pixel reaching 90% of steady state luminance and 10% of steady state luminance. It is shown in Figure 2.

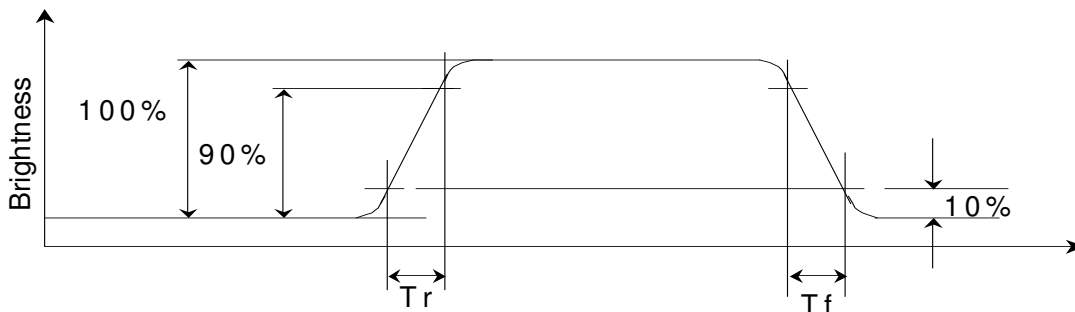

**Figure 2: Response time**

## D. DEFINITION OF VIEWING ANGLE

The viewing angle is defined as Figure 3. Horizontal and vertical (H & V) angles are determined for viewing directions where luminance varies by 50% of the perpendicular value.

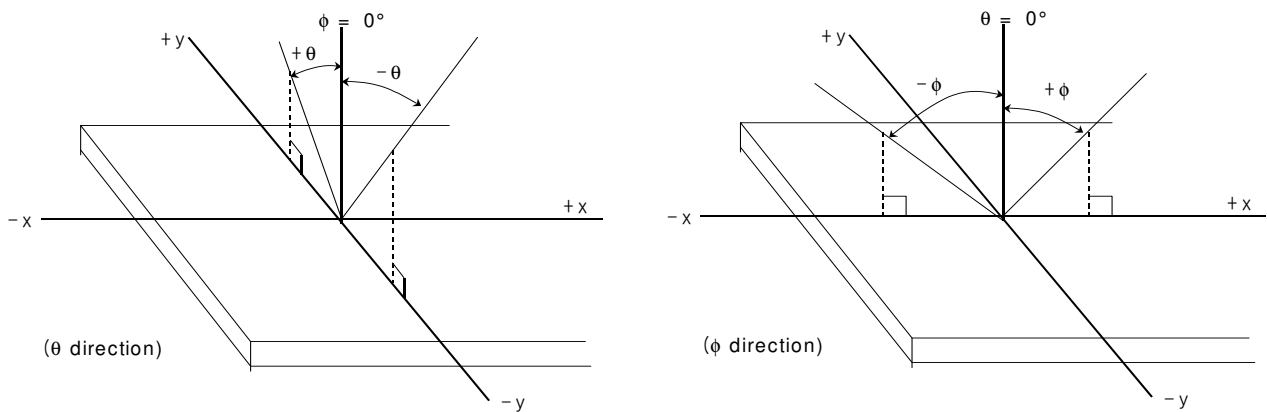
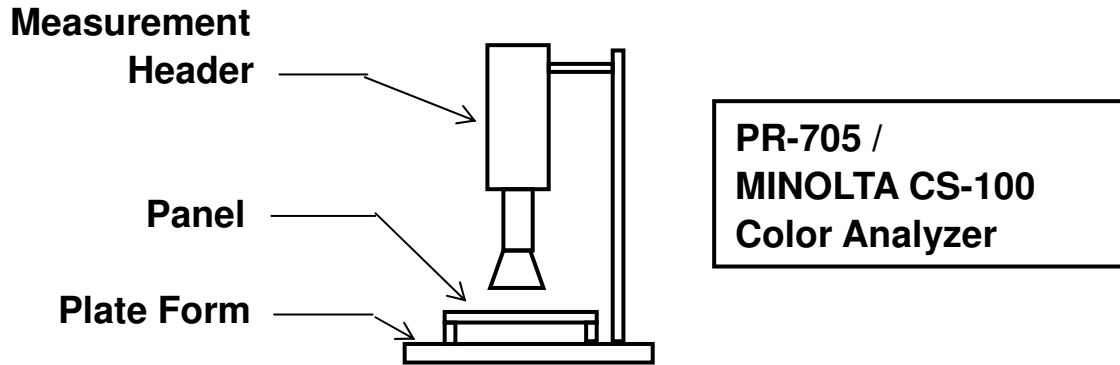

**Figure 3: Viewing Angle**

## APPENDIX 2: MEASUREMENT APPARATUS

### A. LUMINANCE/COLOR COORDINATE

PHOTO RESEARCH PR-705, MINOLTA CS-100



### B. CONTRAST / RESPONSE TIME / VIEW ANGLE

WESTAR CORPORATION FPM-510

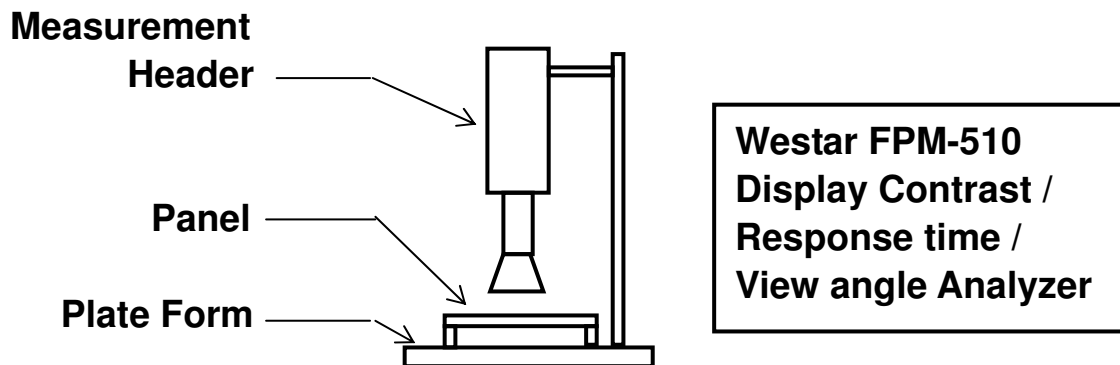



**C. ESD ON AIR DISCHARGE MODE**

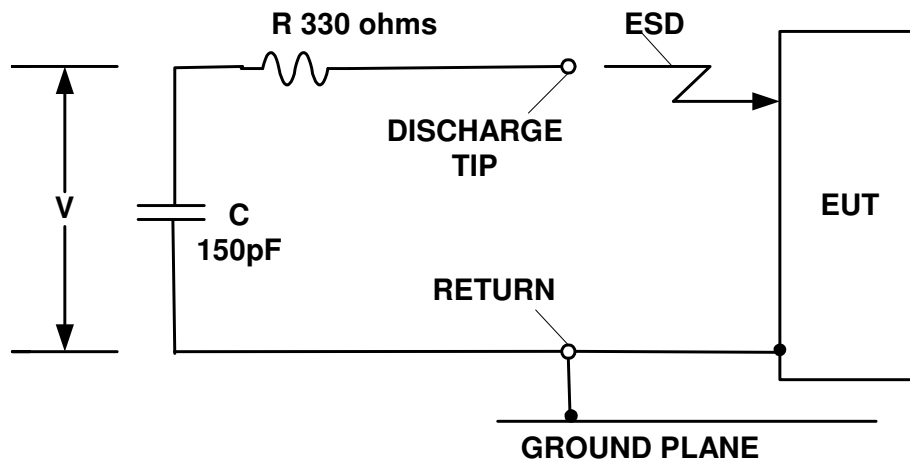

### APPENDIX 3: PRECAUTIONS FOR USING THE OLED MODULE

#### *Precautions for Handling*

1. When handling the module, wear powder-free antistatic rubber finger cots, and be careful not to bend and twist it.
2. The OLED module is consisted of glass and film, and it should avoid pressure, strong impact, or being dropped from a high position.
3. The OLED module is an electronic component and is subject to damage caused by Electro Static Discharge (ESD). And hence normal ESD precautions must be taken when handling it. Also, appropriate ESD protective environment must be administered and maintained in the production line. When handling and assembling the panel, wear an antistatic wrist strap with the alligator clip attached to the ground to prevent ESD damage on the panel. Also, ground the tools being used for panel assembly and make sure the working environment is not too dry to cause ESD problems. Antistatic wrist strap should touch human body directly instead of gloves. (See below photos).

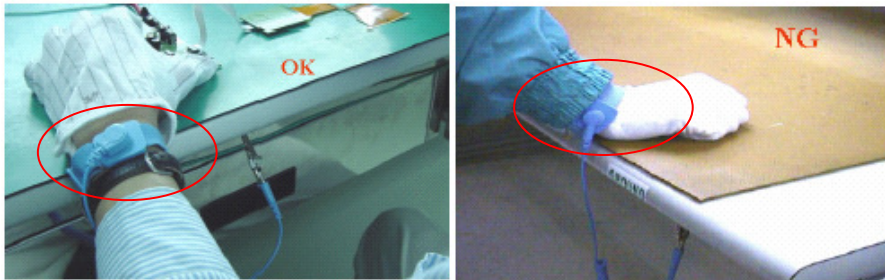

4. Take out the panel one by one from the holding trays for assembly, and never put the panel on top of another one to avoid the scratch.
5. Avoid jerk and excessive bend on TAB/FPC/COF, and be careful not to let foreign matter or bezel damage the film.
6. When handling and assembling the module (panel + IC), grab the panel, not the TAB/FPC/COF.
7. Use the tweezers to open the clicks on the connector of PCB before the insertion of FPC/COF, and click them back in. Once the FPC/COF sits properly in the connector, use the tweezers to avoid the damages.



8. Please do not bend the film near the substrate glass. It could cause film peeling and TAB/FPC/COF damage. For TAB, It should bend the slit area as actual OLED it is. For FPC or COF, it is suggested to follow below pictures for instruction (distance between substrate glass and bending area >1.5mm; R>0.5mm).

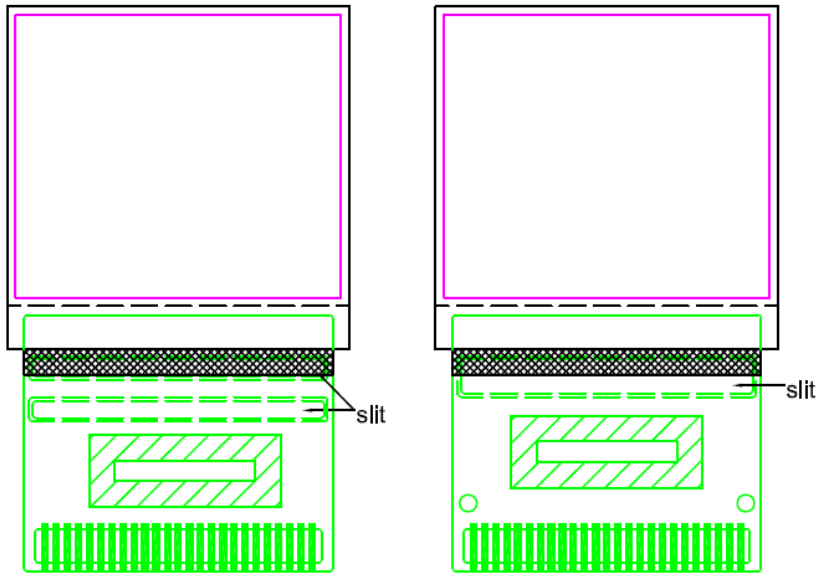

TAB

TAB

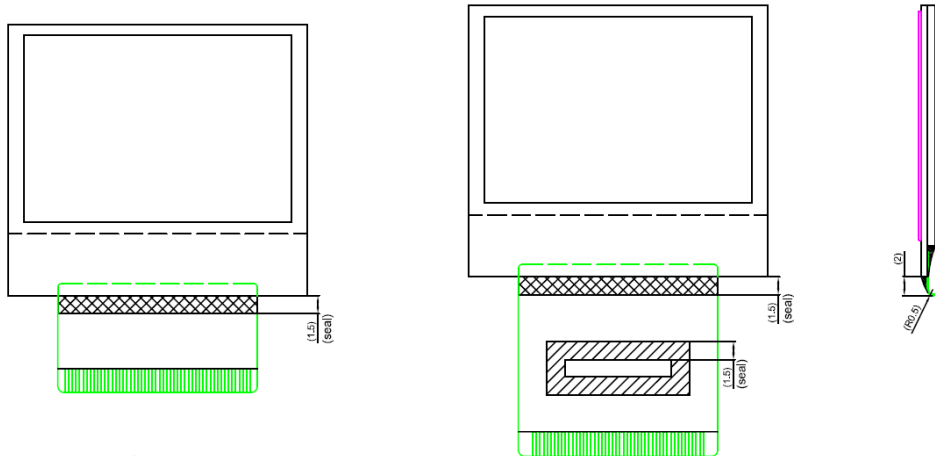

FPC

COF

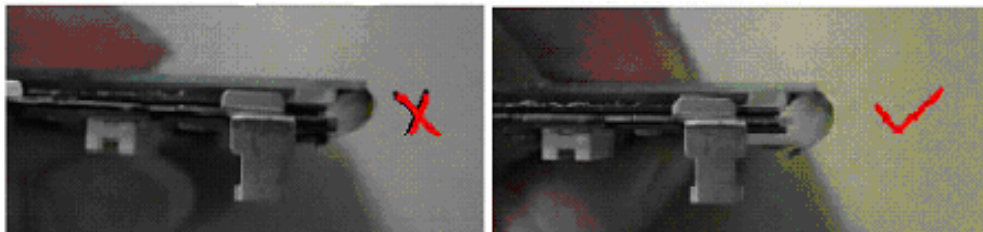

9. Avoid bending the film at IC bonding area. It could damage the IC ILB bonding. It should avoid bending the IC seal area. Please keep the bending distance >1.5mm.

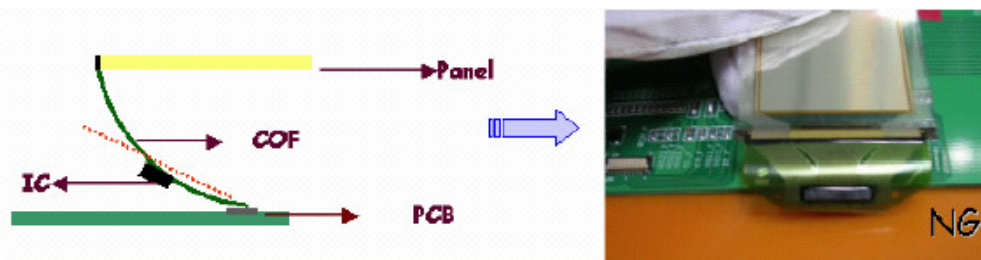
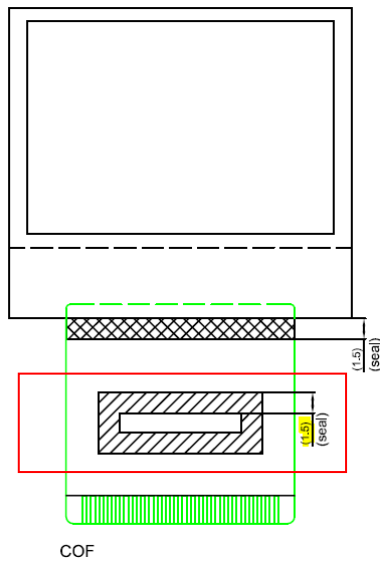

10. Use both thumbs to insert COF into the connector when assembling the panel. Please refer to the photo.

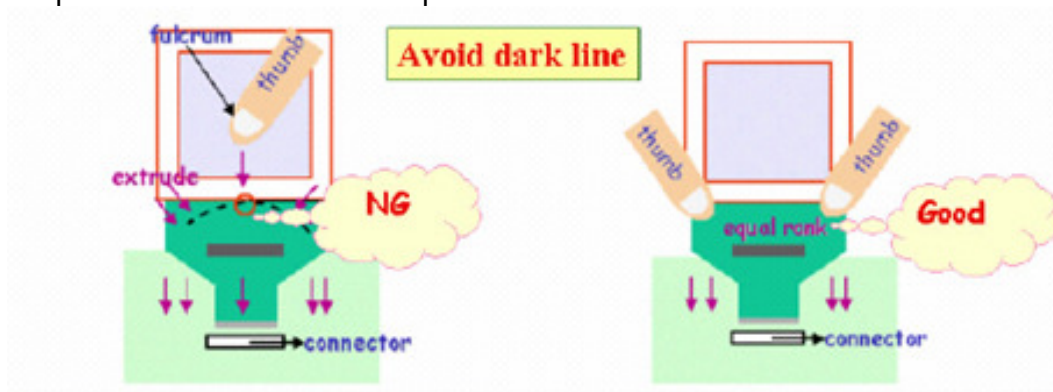

11. The working area for the panel should be kept clean. If the panel is accidentally dropped on the floor, do visual inspection of the panel first. Please use clean-room wiping cloth moistened with alcohol to wipe it off if dirt or grease stains the panel.

12. Do not wipe the pin of film and polarizer with the dry or hard materials that will damage the surface. When cleaning the display surface, use the soft cloth with solvent, IPA or alcohol, to clean.
13. Protection film is applied to the surface of OLED panel to avoid the scratch. Please remove the protective film before assembling it. If the OLED panel has been stored for a long time, the residue adhesive material of the protective film may remain on the display surface after remove the protective film. Please use the soft cloth with solvent, IPA or alcohol, to clean.
14. When hand or hot-bar soldering TAB/FPC onto PCB, make sure the temperature and timing profiles to meet the requirements of soldering specification (the specification depends on the application or optimized by customer) to prevent the damage of IC pins by inappropriate soldering.
15. Solder residues arise from soldering process have to be cleaned up thoroughly before the module assembly.
16. Use the voltage and current settings listed in the specification to do the function test after the module assembly.
17. Suggestion for soldering process:
  - i. TAB Lead- free soldering hot bar process
    1. Use pulse heated bonding tool equipment
    2. Material: Sn/Ag/Cu lead-free solder paste with typical 25um thickness on PCB pad. The TAB pin size and shape may be different, please base on the production line to adjust the thickness of PCB pad and temperature.
    3. Bonding Force:--4kg per centimeter square as the starting point.
    4. Suggested bonding tool temperature & time profile is as below for reference. Since there are differences in TAB soldering pins, soldering technicians' skills, mechanism...etc., the soldering conditions must be adequately tuned.

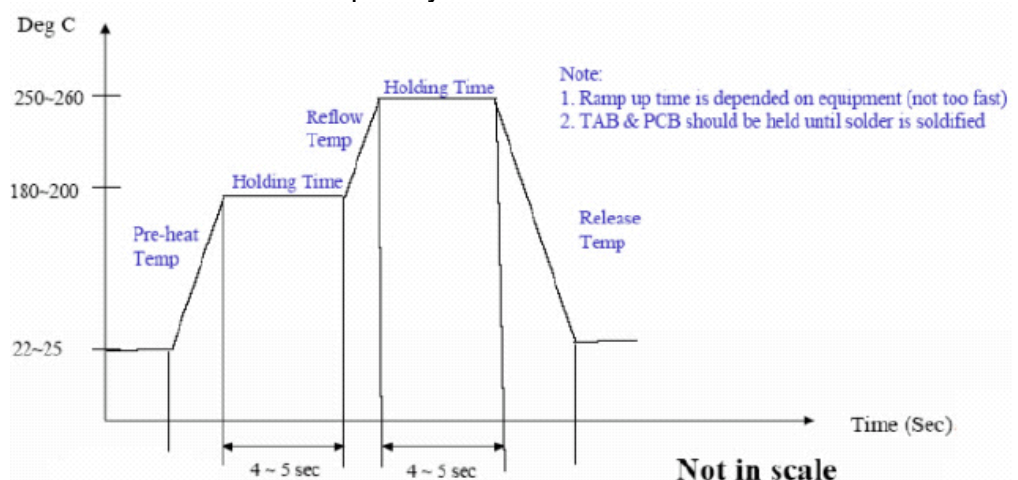

- ii. TAB Lead- free soldering wire process
  - In case of manual soldering (Lead- free solder wire)
  - 1. Solder wire contact iron directly:  $280\pm 5^{\circ}\text{C}$  at 3-5secs
  - 2. Solder wire contact TAB lead directly (near iron but not contact):  $380\pm 5^{\circ}\text{C}$ , 3-5secs
  - 3. Since there are differences in TAB soldering pins, soldering technicians' skills, mechanism...etc., the soldering conditions must be adequately tuned.
- iii. High temperature will result in rapid heat conduction to IC and might cause damage to IC, so please keep the temperature below  $380^{\circ}\text{C}$ . Also, avoid damaging the polyimide and solder resist which might take place at high temperatures. Refold cycles base on the de-soldering status, if the plating of pin was damaged, it can not be used again.

## Precautions for Electrical

### 1. Design using the settings in the specification

It is very important to design and operate the panel using the settings listed in the specification. It includes voltage, current, frame rate and duty cycle... etc. Operation the OLED outside the range of the specification should be entirely avoided to ensure proper operation of the OLED.

### 2. Maximum Ratings

To ensure the proper operation of the panel, never design the panel with parameters running over the maximum ratings listed in the specification. Also the logic voltages such as VIL and VIH have to be within the specified range in the specification to prevent any improper operation of the panel.

### 3. Power on/off procedure

To avoid any inadvertent effects resulting from inappropriate power on/off operations, please follow the directions of power on/off procedure on page 6. Any operation that does not comply with the procedure could cause permanent damage of the IC and should be avoided. When the logic power is not on, do not activate any input signal. Abrupt shutdown of power to the module, while the OLED panel is on, would cause OLED panel malfunction.

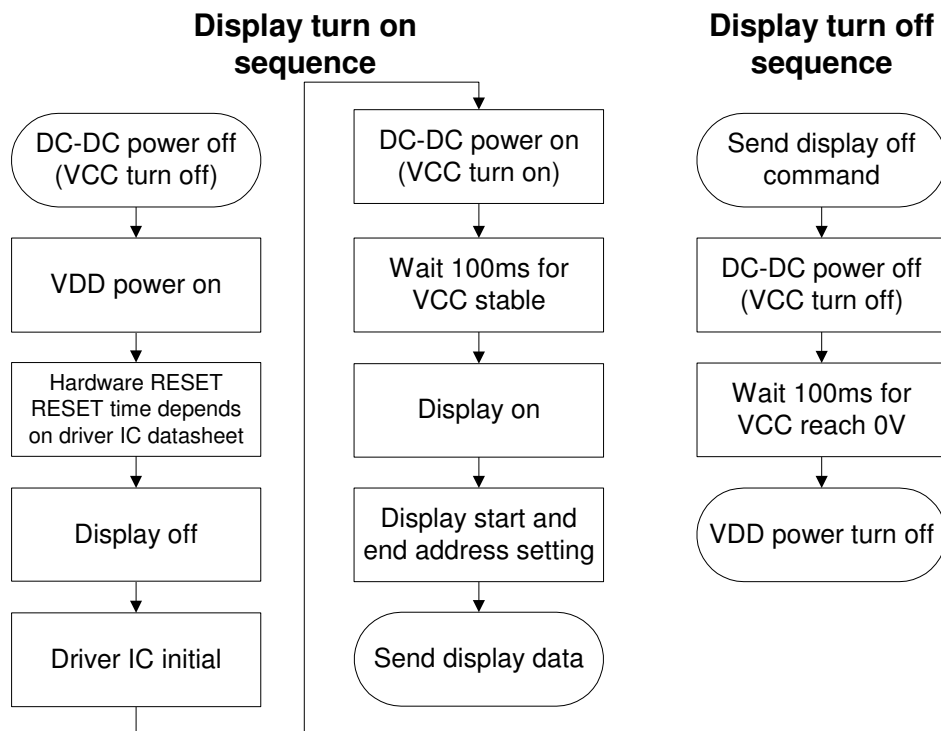

#### 4. Power savings

To save power consumption of the OLED, please use partial display or sleep mode when the panel is not fully activated. Also, if possible, make the black background to save power.

The OLED is a self-luminous device and a particular pixel cluster or image can be lit on via software control. So power savings can be achieved by partial display or dimming down the luminance. Depending on the application, the user can choose among Ultra Bright Mode, Normal Operation Mode, and Sleeping Mode. The power consumption is almost in directly proportion to the brightness of the panel, and also in directly proportion to the number of pixels lit on the panel. The customer can save the power by the use of black background and sleeping mode. One benefit from using these design schemes is the extension of the OLED lifetime.

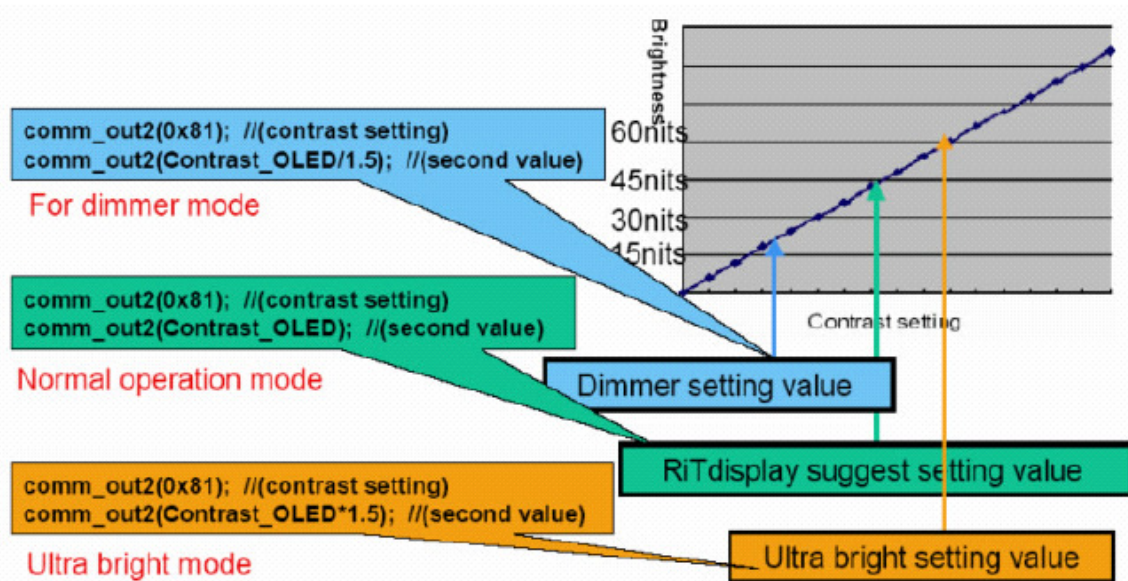

#### 5. Adjusting the luminance of the panel

Although there are a couple of ways to adjust the luminance of the panel, it is strongly recommended that the customer change the contrast setting to adjust the luminance of the panel. Adjusting voltages to achieve desired luminance is not allowed. Be aware that the adjustment of luminance would accompany the change of lifetime of the panel and its power consumption as well.

#### 6. Residual Image (Image Sticking)

The OLED is a self-emissive device. As with other self-emissive device or displays consisting of self-emissive pixels, when a static image frozen for a long period of time is changed to another one with all-pixels-on background, residual image or image sticking is noticed by the human eye. Image sticking is due to the luminance difference or contrast between the pixels that were previously turned on and the pixels that are newly turned on. Image sticking depends on the luminance decay curve of the display. The slower the decay, the less prominent the image sticking is. It is strongly recommended that the user employ the following three strategies to minimize image sticking.



1. Employ image scrolling or animation to even out the lit-on time of each and every pixel on the display, also could use sleeping mode for reduced the residual image and extend the power capacity.
2. Minimize the use of all-pixels-on or full white background in their application because when the panel is turned on full white, the image sticking from previously shown patterns is the most revealing. Black background is the best for power savings, greatest visibility, eye appealing, and dazzling displays
3. If a static logo is used in the reliability test, change the pattern into its inverse (i.e., turn off the while pixels and turn on the previously unlit pixels) and freeze the inverse pattern as long as the original logo is used, so every pixel on the panel can be lit on for about the same time to minimize image sticking, caused by the differential turn-on time between the original and its reverse patterns.

**Black Background**



**Scrolling example**

Frame1

Frame2

Frame3

Frame4

Frame5

Example: setup and start

```

comm_out2(0x26); // scrolling setup
comm_out2(0x08); // scrolling numbers/step
comm_out2(0x00); // start page
comm_out2(0x00); // scrolling step/frame
comm_out2(0x08); // end page
comm_out2(0x2F); // start
        
```

Example: stop

```

comm_out2(0x2E); //stop
        
```

## *Precautions for Mechanical*

### **1. Cushion or Buffer tape on the cover glass**

It is strongly recommended to have a cushion or buffer tape to apply on the panel backside and front side when assembling OLED panel into module to protect it from damage due to excessive extraneous forces.

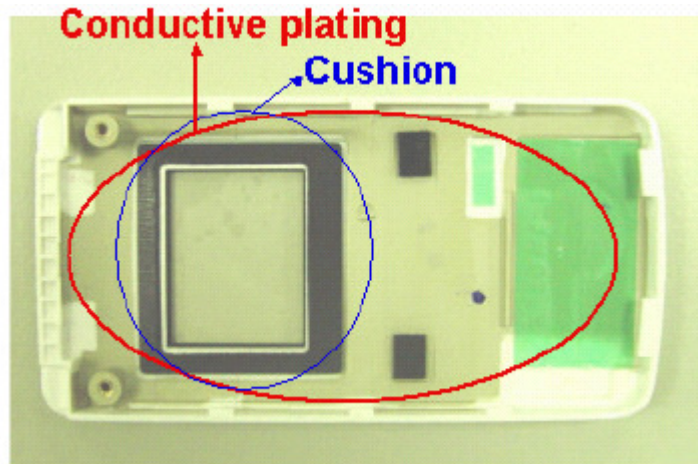

It is recommended that a plating conductive layer be used in the housing for EMI/EMC protection. And, the enough space should be reserved for the IC placement if the IC thickness is thicker than the TAB film when customer design the PCB.

### **2. Avoid excessive bending of film when handling or designing the panel into the product**

The bending of TAB/COF/FPC has to follow the precautions indicated in the specification, extra bending or excessive extraneous forces should be avoided to minimize the chances of film damage. If bending the film is necessary, please bend the designated bending area only. Please refer to items 8 and 9 of Precautions for Handling for more information.

## *Precautions for Storage and Reliability Test*

### **1. Storage**

Store the packed cartons or packages at  $25^{\circ}\text{C} \pm 5^{\circ}\text{C}$ ,  $55\% \pm 10\% \text{RH}$ . Do not store the OLED module under direct sunlight or UV light. For best panel performance, unpack the cartons and start the production of the panels within six months after the reception of them.

### **2. Reliability Test**

RiTdisplay only guarantees the reliability of the OLEDs under the test conditions and durations listed in the specification.